

# Model 1A4324 GJ Hood Mount Installation

1. Review the illustrations shown (Figure 1) and select the one (A, B, or C) that matches your application.

**NOTE:** Illustrations shown are for LEFT hand mounting. RIGHT hand mounting opposite.

**FIGURE 1**

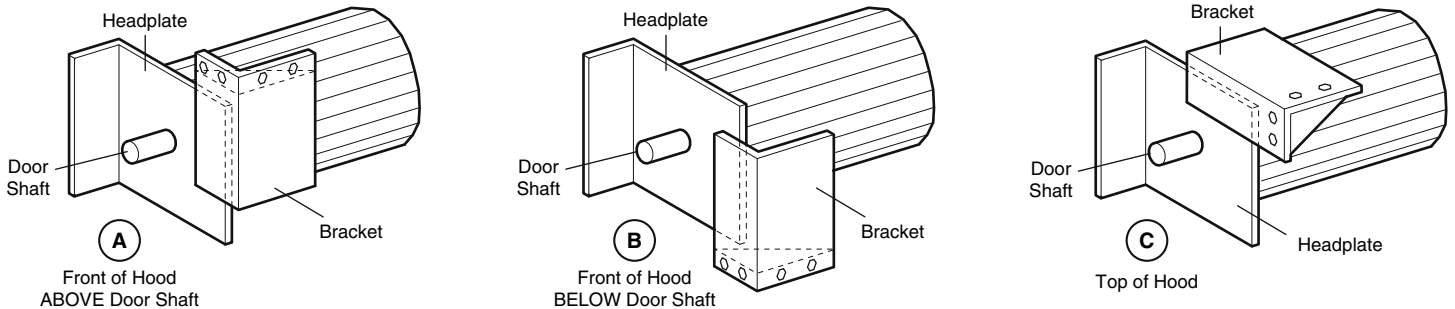

2. Attach the gusset to the bracket using the four 3/8" x 1" cap screws and hardware shown. Then tighten.

**NOTE:** For Application 1A attach gusset to end of bracket marked A, etc., (Figure 2).

3. Install the four 3/8" x 1-1/2" cap screws and hardware shown. Do not tighten.

4. Temporarily locate and clamp bracket in correct position on headplate.

**NOTE:** Leave a minimum of 1" between bracket and headplate (Figure 3).

5. Place drive sprocket on operator output shaft and driven sprocket on door shaft. Do not insert keys or tighten set screws.

6. Hold operator in position on bracket and wrap #50 roller chain around drive sprocket and driven sprocket to determine length of chain required.

**NOTE:** Lockwasher and nut will need to be removed and replaced on operator mounting screws to perform this step.

**NOTE:** Observe location of mounting screws in slots of bracket. Leave room in slots for chain tensioning. For Application 1A, screws should be close to bottom of slot with chain installed, for Application 1B, screws should be close to top of slot, and for Application 1C, screws should be close to end of slot towards wall. Readjust bracket if necessary and repeat procedure before cutting chain.

**NOTE:** Make certain that operator shaft is above, below or in front of door shaft, never in-line. 7. Remove operator from bracket and cut #50 chain to required length.

**FIGURE 2**

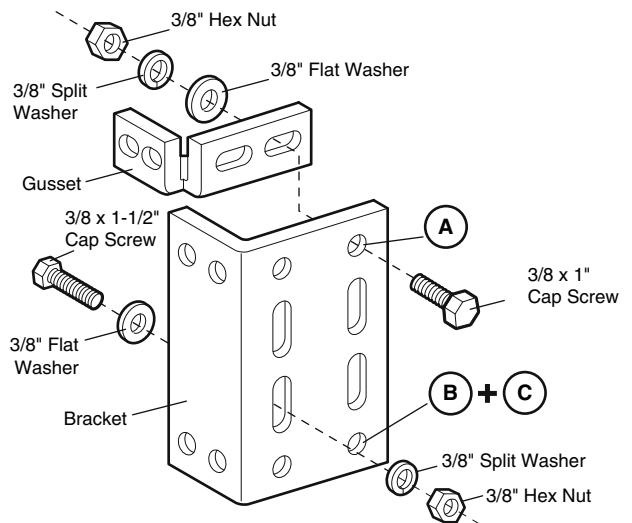

**FIGURE 3**

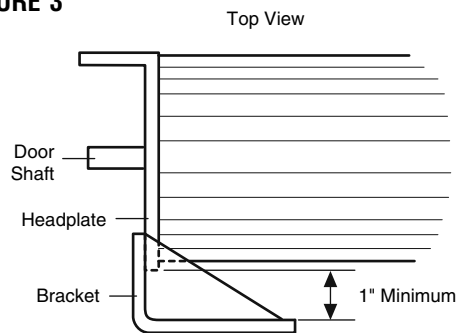

**WARNING:** This product can expose you to chemicals including lead, which are known to the State of California to cause cancer or birth defects or other reproductive harm. For more information go to [www.P65Warnings.ca.gov](http://www.P65Warnings.ca.gov)

8. Permanently attach bracket to headplate in the location determined in Step 6. Welding is recommended for this procedure.
9. Attach operator to bracket using 3/8 x 1-1/2 mounting screws and hardware. Do not tighten.
10. Insert key in driven sprocket and align driven sprocket with drive sprocket. Tighten set screws. Do not place key in drive sprocket at this time.
11. Wrap #50 chain around drive and driven sprocket and connect ends using #50 master link.
12. Remove slack from chain by moving operator and mounting screws in bracket slots. Tighten mounting screws.

**NOTE:** *Keyway in operator output shaft may not be aligned with keyway in drive sprocket. Complete electrical connections to operator (refer to manual) then operate unit with 3 button control until keyways align. Insert key in drive sprocket and tighten set screws. Complete the installation according to the owner's manual.*