

powermaster

CH

Door Operator for Carwash Type Applications on Sectional Doors and Rolling Service Doors and Grilles.

Standard Features:

- Heavy Duty V-Belt and Chain Reduction
- Floor Level Disconnect w/Chain Hoist Interlock for Manual Operation
- High Starting Torque Motor with Full Overload Protection
- Solid State Circuitry with Feedback LEDs
- On board Open/Close/Stop Buttons for Service and Adjustments
- Field Adjustable Built-in Functions
- Auto Detect Monitored Photo Beam for Simplified Installation

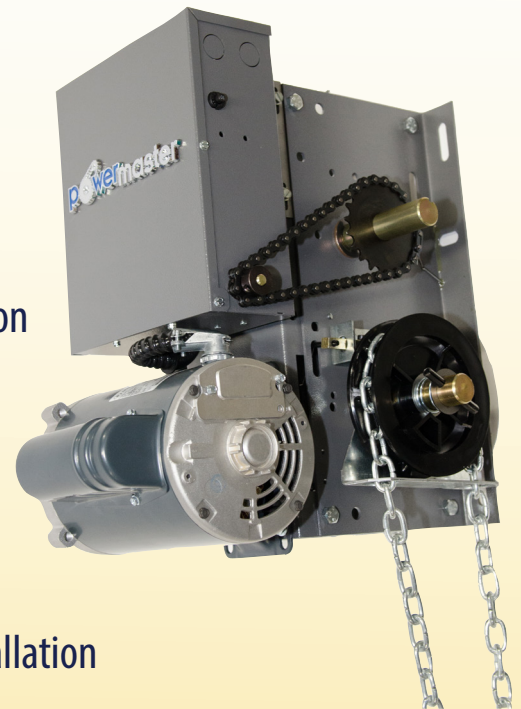

Complete selection of control stations & accessories are available.

All door operators are required to have a monitored safety system, such as monitored photo eyes and/or monitored 2 or 4 wire obstruction sensing edge. In addition, an ancillary device may be used. The primary device must be a constantly monitored, anti entrapment/safety device.

www.VEpower.net

[Facebook.com/PowerMasterOperators](https://www.facebook.com/PowerMasterOperators)

SERVICING THE INDUSTRY SINCE 1969

CH

Architectural Specs

Supply PowerMaster model CH Industrial Duty Hoist operator for Carwash type applications on Sectional Doors and Rolling Service Doors and Grilles. Primary reduction is by heavy duty V-Belt Drive. Secondary reduction is by chain and sprocket arrangement. Reduction stages arranged so that mechanism is self locking when torque is applied at output shaft. All reduction shafts are a minimum of 1" in diameter, supported by bronze oilite bearings. Operator provides an adjustable torque limiting clutch.

Motor is of the high starting torque, totally enclosed fan cooled continuous duty industrial type, protected from overload by a current sensing or thermal type overload device. Motor controller is a heavy duty, full voltage, across the line, magnetic reversing contactor, that is mechanically and electrically interlocked. Electrical components installed in a NEMA 4 enclosure integral to the operator. A transformer is provided to reduce control voltage to 24 VAC. Separate terminal strips provided for connection of power supply line and all control devices. Operator is wired for an open/close/stop control station.

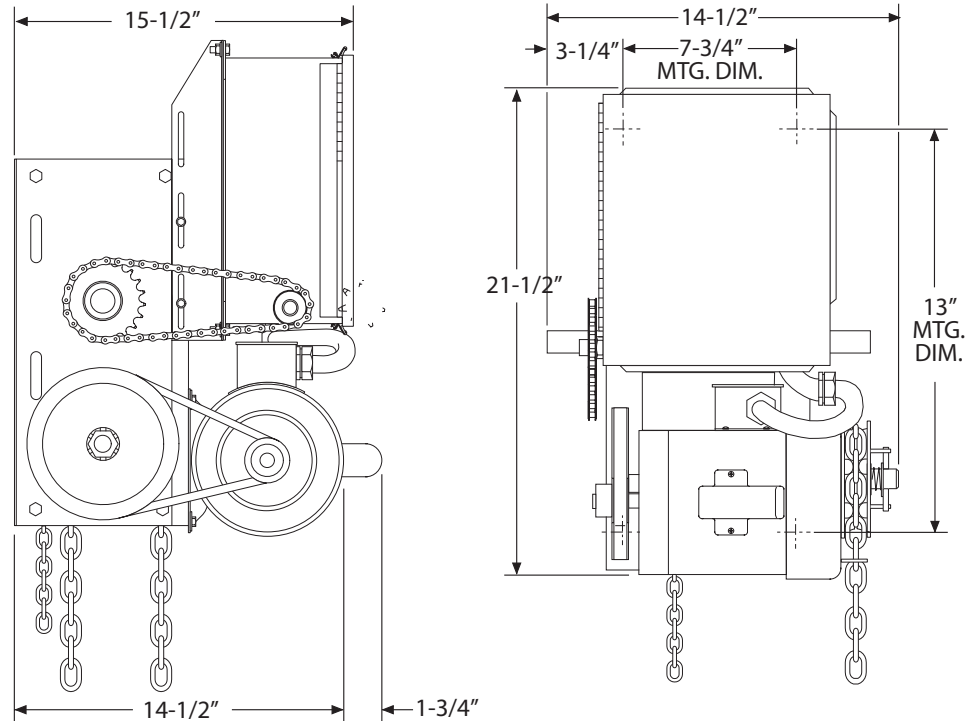

Control circuit provides instant reverse motor wiring on single phase operators. Positive chain driven, rotary type limit switches are provided to limit full open and close travel of door. Limit switch adjustment is not affected by removal of motor or by manual operation of door. A floor level manual hoist chain is provided for emergency operation of door. An electrical interlock switch is provided to disable control circuit while manual hoist chain is engaged. Final drive chain is a #50 or larger roller chain. Operator is capable of right or left hand mounting in either a vertical or horizontal position.

CAUTION

A moving door can cause serious injury or death!

Carefully read and follow all safety instructions, precautions, and guidelines when installing and using this product.

Motorized doors are for vehicles only. Pedestrians must use a separate entrance. **NO ONE SHOULD CROSS THE PATH OF A MOVING DOOR!**

Proper reversing devices must be installed to avoid all hazards and entrapment. Eliminate all hazards and entrapment areas.

Warning signs must be permanently installed and visible to traffic and pedestrians.

Never allow children to operate or play with controls.

Follow UL 325 and ASTM F220-02 standards.

Do not install this product unless all hazards and entrapment points are protected.

