

QUICKSTART "BASIC" GUIDELINES FOR MODEL 9200 "FULL OPEN": MOUNTED ON THE PEDESTAL MOUNTING STAND

UL 325 August
2018 Standard



120 S. Glasgow Avenue
Inglewood, California 90301
U.S.A.

Fits on All 9200 Models.
Standard with 9230, 9235, 9240 and 9245 Models

Assemble Pedestal Mounting Stand

See instruction sheet with pedestal kit for assembly.

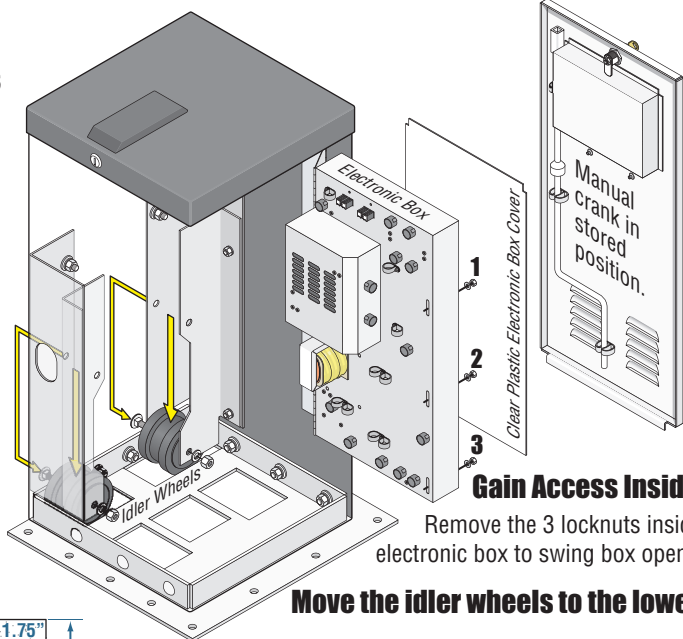
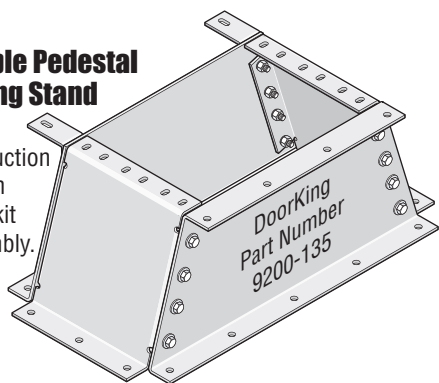

Caution:
Never attempt to manually operate the 9200 until you have verified that power has been shut-off.

Gain Access Inside Operator

Remove the 3 locknuts inside the electronic box to swing box open.

Move the idler wheels to the lower position.

Concrete Pad Dimensions, Pedestal Mounting Stand and Conduit Positions

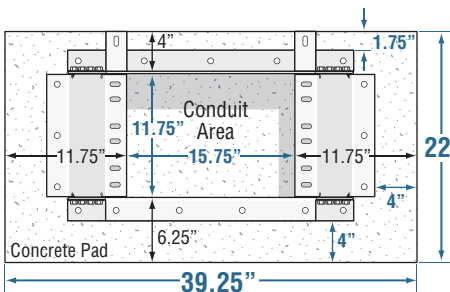

Concrete pad **MUST** be level!

Opening direction **OFF** setting.

Operator MUST be parallel to gate!

Opening direction **ON** setting.

Top Views

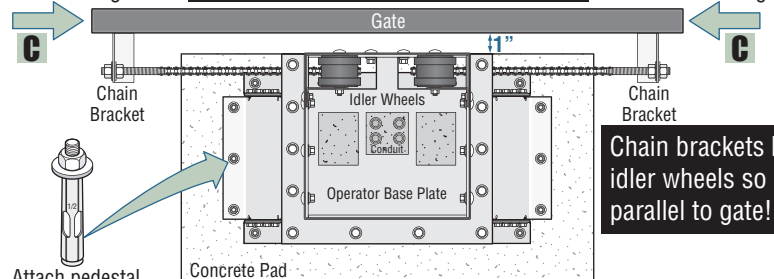

Chain brackets **MUST** align with idler wheels so chain stays parallel to gate!

Attach pedestal stand with sixteen (16) 1/2" x 3" sleeve anchors (not supplied) after concrete pad has been poured and has cured.

Warning Signs

Permanently mount signs on **BOTH** sides of the gate area and make sure they are easily visible.

Pedestal mounting stand **MUST** be level!

Chain brackets **MUST** be mounted so the chain remains the same height as it is on the idler wheels!

Side Views

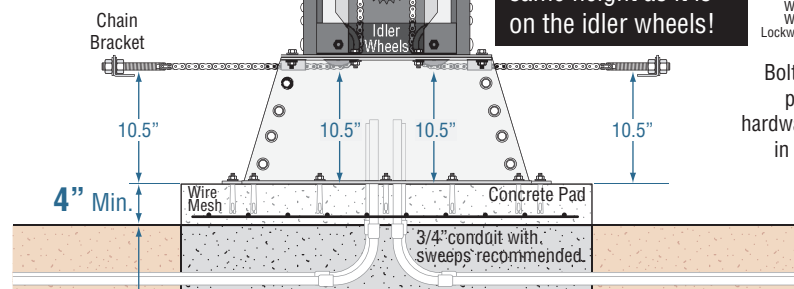

Pad depth is determined by soil conditions and local building codes. Minimum depth is 18 inches. Reinforced concrete recommended.

Connect Chain to the Gate

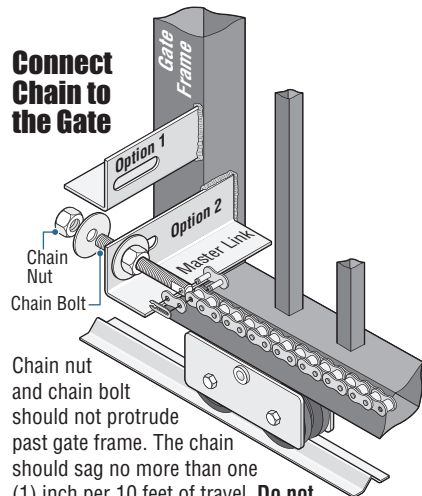

Chain nut and chain bolt should not protrude past gate frame. The chain should sag no more than one (1) inch per 10 feet of travel. **Do not over tighten the chain.**

"Optional" Chain Tray Kit

Recommended for gates longer than 20 ft. to support the weight of the chain. DoorKing offers a chain tray and supporting brackets in 10 ft. sections to fit any length gate (DoorKing Part Number 2601-270, 10 Ft. section). See instruction sheet with chain tray kit for installation.

Limit Switches

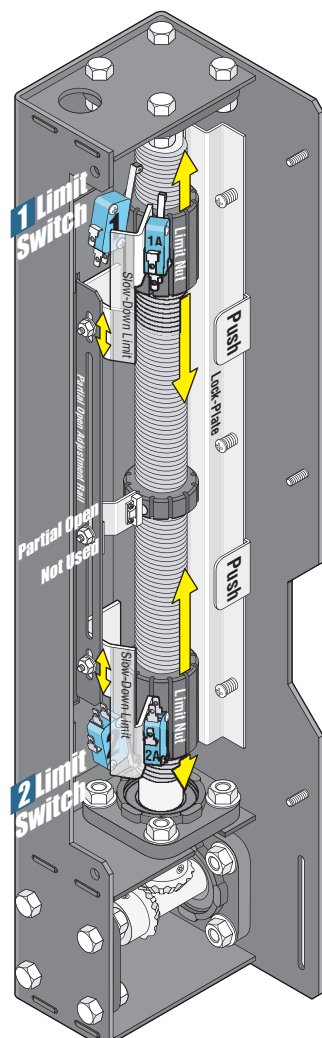

With power **OFF**, push and hold the lock plate down where shown to adjust the Open and Close limit nuts. After adjusting the limit-nuts, be sure that the lock-plate is engaged in the slots on the limit-nuts to prevent them from rotating. The slow-down limits on all models but the 9210 will move up or down 3/4 inch. **DO NOT** remove the slow-down limit assembly from the 3/4 inch slot and re-attach it in the longer slot on the partial open adjustment rail to gain further adjustment. **This will cause mechanical damage to the switch assembly when the operator is activated.** Turn power **ON** and activate the gate operator. Re-adjust the limit nuts as necessary for full-open and full-close gate travel. After you are satisfied with the gate limit settings, the speed control knob can then be adjusted on all models but the 9210 to personal preference.

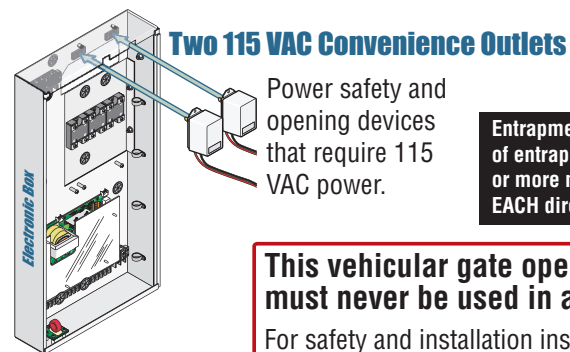

Two 115 VAC Convenience Outlets

Power safety and opening devices that require 115 VAC power.

Entrapment Protection must be provided for the gate system where the risk of entrapment or obstruction exists. The operator will **NOT** run without one or more monitored type B1 or B2 external entrapment protection devices in **EACH** direction of gate travel (minimum of 2 external devices required).

This vehicular gate operator is designed for Class III and Class IV applications only and must never be used in applications serving the general public.

For safety and installation instructions, please refer to the Installation/Owner's manual.

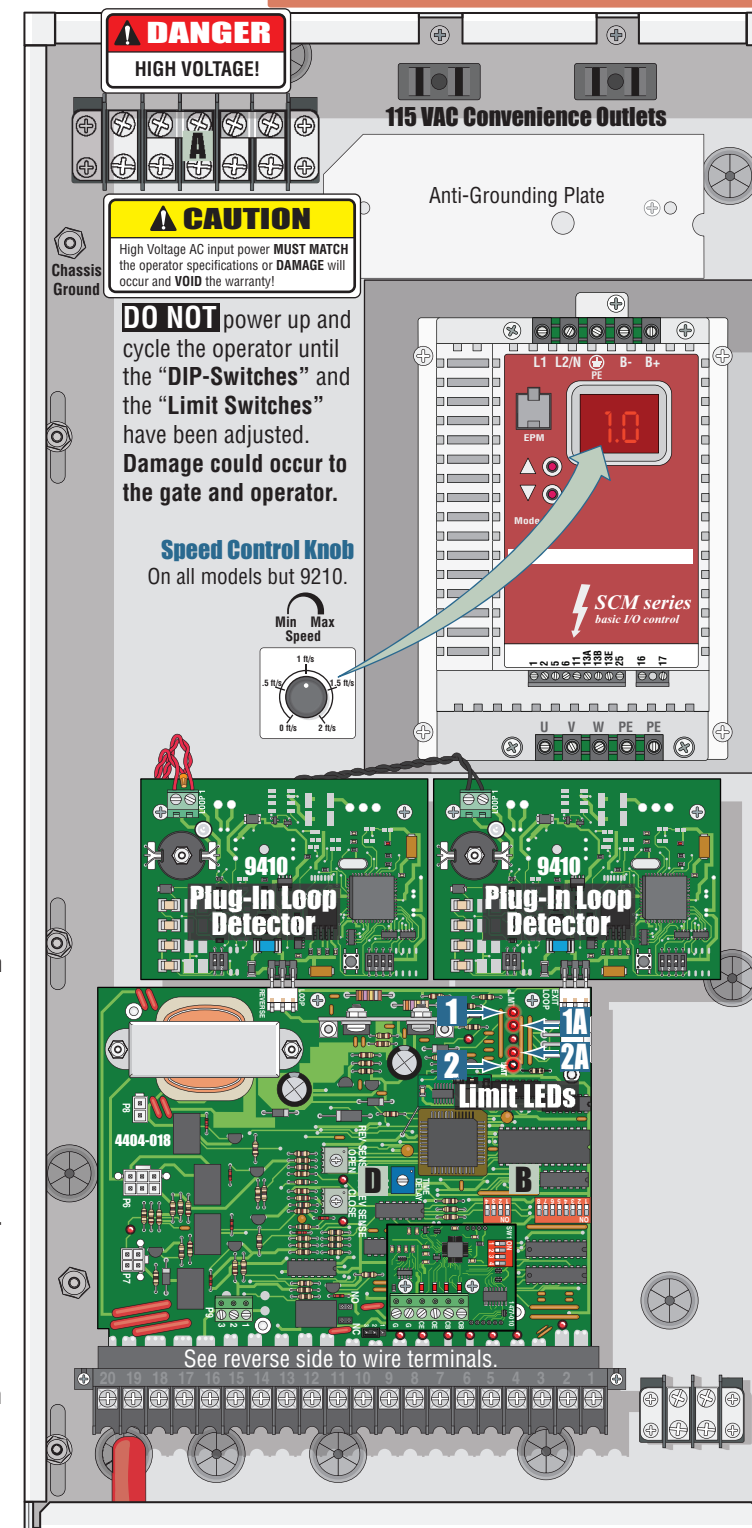

DANGER
HIGH VOLTAGE!

CAUTION
High Voltage AC input power **MUST MATCH** the operator specifications or **DAMAGE** will occur and **VOID** the warranty!

DO NOT power up and cycle the operator until the "DIP-Switches" and the "Limit Switches" have been adjusted. **Damage could occur to the gate and operator.**

Speed Control Knob
On all models but 9210.

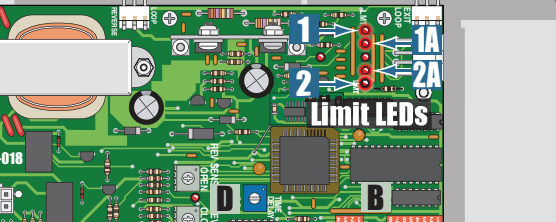
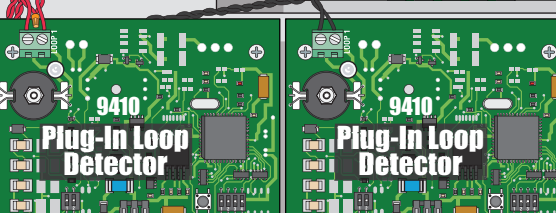
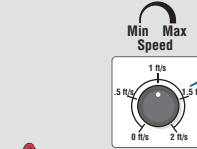

See reverse side to wire terminals.

High Voltage Connection

GATE OPERATOR MUST BE PROPERLY GROUNDED!
Tip: It is recommended that a surge suppressor be installed on the high voltage power lines.

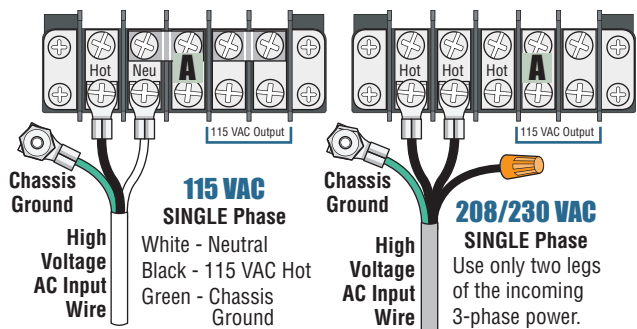

VERIFY Input AC power **MATCHES** your specific operator power **BEFORE** wiring!

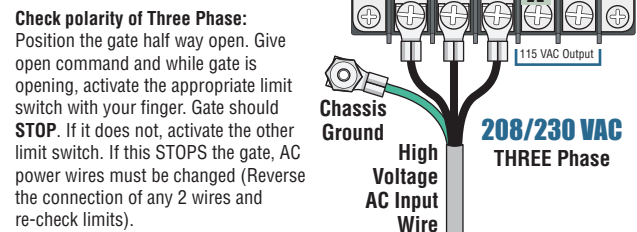

Check polarity of Three Phase:
Position the gate half way open. Give open command and while gate is opening, activate the appropriate limit switch with your finger. Gate should **STOP**. If it does not, activate the other limit switch. If this **STOPS** the gate, AC power wires must be changed (Reverse the connection of any 2 wires and re-check limits).

DIP-Switches

SW 1 and 2 are Upside-Down on Circuit Board.

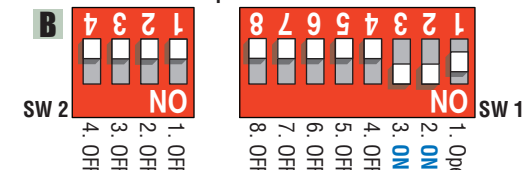

Auto-Close Timer

See reverse side



Adjust 1 to 23 sec.

Plug-In Loop Detectors

Not included - Refer to the Installation/Owner's manual **AND** Loop Information Manual (available from www.doorking.com) for more information on loops and plug-in loop detectors. **Important Note:** DoorKing highly recommends that loops and loop detectors are installed with this slide gate operator. A loop detection system will prevent the gate from automatically opening or closing on a vehicle when it is in the gate's path.

QUICKSTART "BASIC" GUIDELINES FOR MODEL 9200 - DIP-SWITCH AND WIRING REFERENCE

UL 325 August
2018 Standard



120 S. Glasgow Avenue
Inglewood, California 90301
U.S.A.

This vehicular gate operator is designed for Class III and Class IV applications only and must never be used in applications serving the general public.

For safety and installation instructions, please refer to the Installation/Owner's manual.

SW 1 DIP-Switches (Right Hand Side)

SW 1 - Right 8 Switches			
Switch	Function	Setting	Description
1	Changes the direction the operator will open/close the gate.		<p>Opening direction using ON setting. Opening direction using OFF setting.</p> <p>Lower Configuration</p>
2	Auto-Close Timer	OFF	Auto-close timer is OFF. Manual input required to close gate.
		ON	Auto-close timer is ON. Adjustable from 1-23 seconds to close gate.
3	Exit Loop Port Output	Jumper Wire Needed See Manual OFF	The output wired to terminal #4 becomes the output from the loop detector installed in the EXIT loop port. Plug-in loop detector required for "OFF" function.
	Full Open Input	ON	Normal Setting. Terminal #4 is a normal full open input for a single gate operator.
4 and 5	Relay Activation and LED Indicator Light Activation	4-OFF 5-OFF	Relay activates and LED is ON when the gate is fully open.
		4-OFF 5-ON	Relay activates and LED is ON when the gate is not closed.
		4-ON 5-OFF	Relay activates and LED is ON when the gate is opening and open.
		4-ON 5-ON	Relay activates and LED is ON when the gate is opening and closing.
6	Warn Before Operate	OFF	Internal alarm will NOT sound.
		ON	Internal alarm will sound before gate starts and throughout gate's cycle.
7	Reverses Gate	OFF	Normal Setting. Input to terminal #6 and/or reverse loops will REVERSE gate during CLOSE cycle.
	Stops Gate	ON	Input to terminal #6 and/or reverse loops will STOP gate during CLOSE cycle.
8	Quick-Close Timer Override	OFF	Normal Setting. Timer will function normally.
		ON	Opening gate will stop and begin to close as soon as all reversing inputs (Reverse loops, photo sensors) are cleared regardless of the distance the gate has opened.



SW 1
Upside-Down on Circuit Board.

Important: Controls intended for user activation must be located at least six (6) feet away from any moving part of the gate and where the user is prevented from reaching over, under, around or through the gate to operate the controls. Emergency access controls only accessible by authorized personnel (e.g., fire, police, EMS) may be placed at any location in the line-of-sight of the gate.

Main Terminal

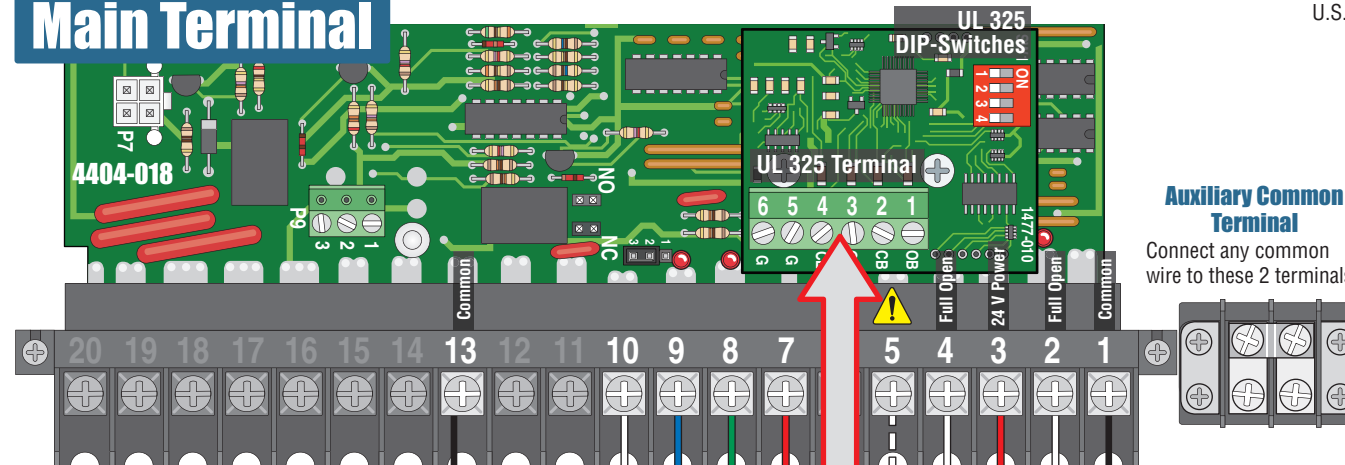

Note: All stand-alone and telephone entry devices must use a separate power source.



SW 1, Switch 3 MUST be ON except for dual operators or exit loop partial open applications.

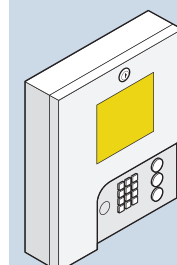

Telephone Entry

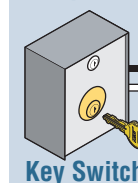

Key Switch

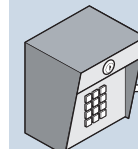

Stand-Alone Keypad

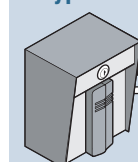

Stand-Alone Card Reader

3-Button Control Station Jumper
Jumper Pins 1 & 2 ONLY when using a 4-wire control station to enable stop terminal #9.

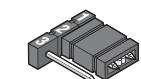

3-Button Control Station

External Entrapment Protection Devices

IMPORTANT: Only 1 monitored Device can be connected to each input. An **OPTIONAL** Expansion Kit (sold separately) will allow connection for additional devices.

IMPORTANT: Photo sensors must use **Normally Closed (NC)** contacts with the beam set for light operate (relay activated when beam is not obstructed). Some manufacturer's photo sensor contacts are labeled as **Normally Open (NO)** but their relay functions the same way as described above. See specific manufacturer's wiring manual for more information about their specific relay function.

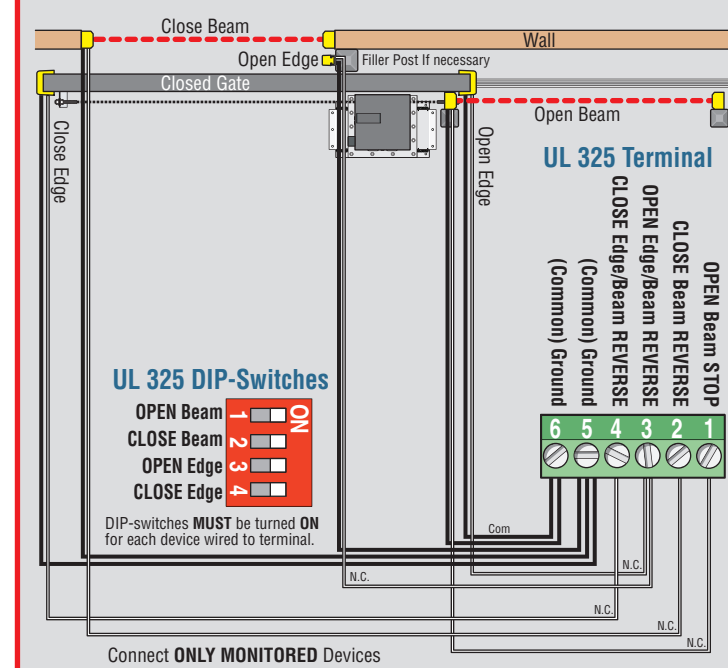

UL 325 DIP-Switches

- OPEN Beam ON
- CLOSE Beam 1
- OPEN Edge 2
- CLOSE Edge 3
- 4

DIP-switches MUST be turned ON for each device wired to terminal.

#5 Terminal Note: Any opening device connected to terminal #5 will open the gate to the partial open setting. External entrapment protection devices will also open the gate to the partial open setting. If the **Inherent Reverse Sensor** gets activated during the close cycle, it will always fully open the gate.

Entrapment Protection must be provided for the gate system where the risk of entrapment or obstruction exists. The operator will NOT run without one or more monitored type B1 or B2 external entrapment protection devices in EACH direction of gate travel (minimum of 2 external devices required).

SW 2 DIP-Switches (Left Hand Side)

SW 2 - Left 4 Switches			
Switch	Function	Setting	Description
1	Self-Test	OFF	Normal Setting. Normal gate operation.
		ON	Self-test mode. Operator MUST be disconnected from gate to run self-test.
2	Gate Opens Uphill	OFF	Normal Setting. Normal gate operation.
		ON	MUST be ON if gate opens UPHILL.
3	Gate Opens Downhill	OFF	Normal Setting. Normal gate operation.
		ON	MUST be ON if gate opens DOWNHILL.
4	Spare	OFF	Leave in the OFF position.

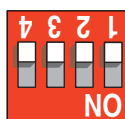

SW 2
Upside-Down on Circuit Board.