

DOLSL/DOLSLK

USER MANUAL



Part No: DOLSL / DOLSLK

V.4.6.17

Dolphin[®]
Access Systems

MOUNTING

1. Install the back plate on the wall as shown in the diagram below.
2. The cover will clip on the upper edge. Push in the bottom part as shown in the diagram.
3. Tighten the non-dropout screw, which is located underneath the reader to fix the reader and the back plate. Installation is complete.

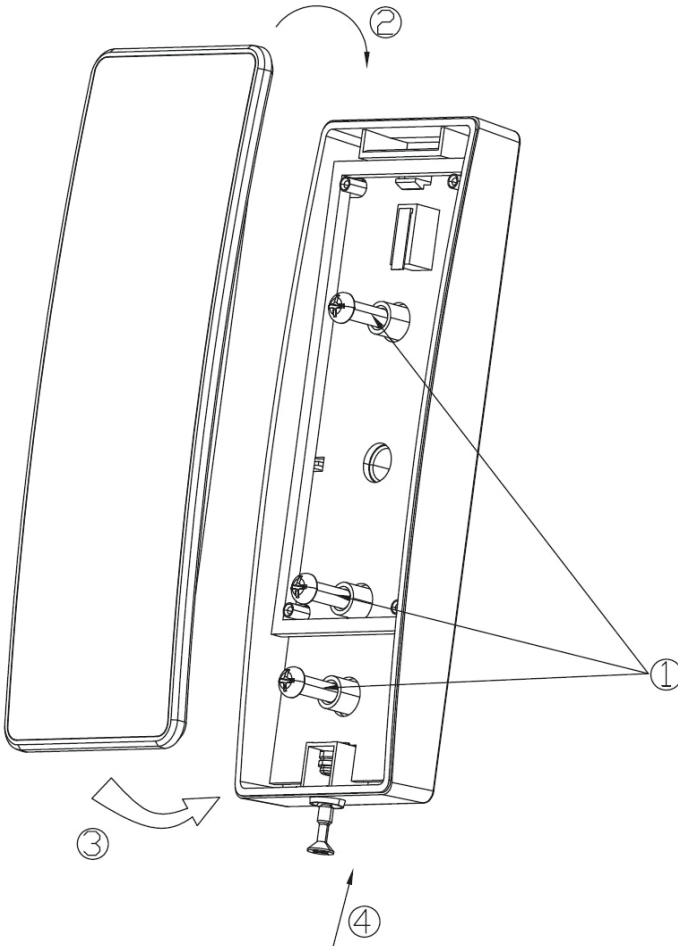

SPECIFICATIONS

Input Voltage (at Reader end)	DC9V~15V	Typical Read range	> 5cm
Operating Current	120mA (max)	Maximum Cable Length	150m
Operating Temperature	-30°C~70 °C		

RECOMMENDATION

1. Linear DC Power Supply
2. 22AWG shielded cable. It's required to do "one-point" ground (as shown in the diagram)

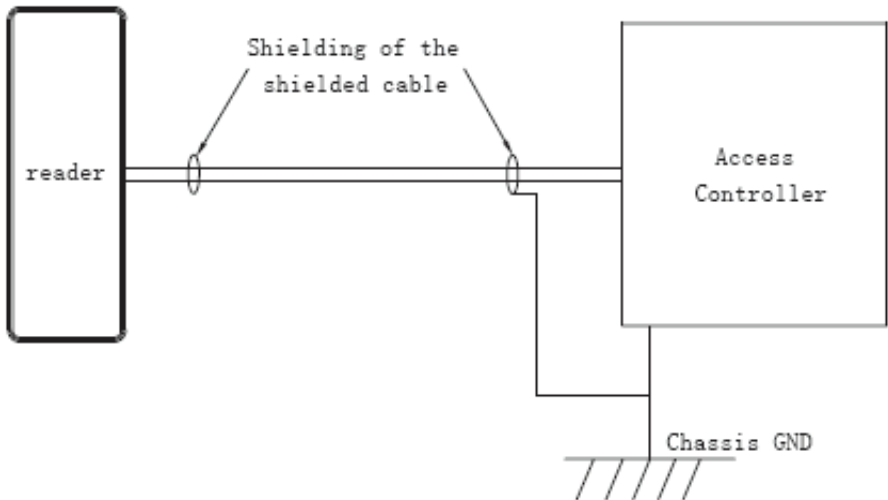

WIRING

Color	Label	Description
Red	+12V dc	Power Supply to the reader
Black	GND	Signal GND
Green	Data0	Wiegand Output data, D0
White	Data1	Wiegand Output data, D1
Yellow	RED LED	RED LED control, active low.
Blue	Green LED	Green LED control, active low
Brown	Buzzer	Buzzer input, active low
Orange	Tamper	Tamper output (open collector, Active low, max 100mA)
Purple	Doorbell	Door bell output (open collector, +5Vdc output \leq 5mA)

PHYSICAL DIMENSIONS

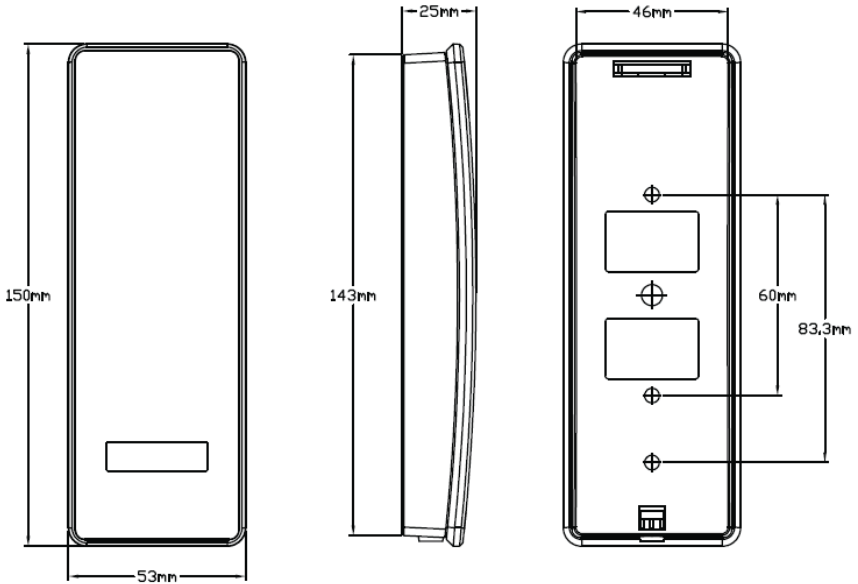

POWER UP SEQUENCES

1. This is a 125 KHz flash reader. When the reader is powered up, the Green border will blink for 5 seconds. The reader will beep once and is now in Ready mode.
2. Present the card. The Blue LED will blink once and the buzzer will beep once.
3. When a card is presented and read by the reader, the card data will be transmitted to the controller. Whether the back-lit of the reader will remain ON, flash or change to Green or Red, depends on the Green and Red LED inputs on the access controller.
4. For the number pad reader, when a number is pressed and successfully detected, the back-lit LED under the number will flash one time and the buzzer will beep once. The pin being entered will output by default at a 4 bit burst.

TROUBLESHOOTING

Trouble List	Solution
No Response when Power Up	<p>Disconnect the power and confirm that the power supply cable is correctly connected (See "Wiring" above).</p> <p>Check the input voltage is sufficient (See "Specifications" above).</p>
Auto Restart	<p>Check that the input voltage is sufficient (See "Specifications" above).</p>
Cannot read card number correctly	<p>Check the format setting on the controller if it is the same as the card format. Use approved card (known format and Facility Code) to test.</p> <p>Check if the shield cable is correctly connected to Ground at ONE point only.</p>
Reader beeps but No card data info	<p>Check if data 0 & data 1 cables are correctly connected (See "Wiring" above).</p> <p>Check the input voltage at the card reader is correct (See "Specifications" above).</p>
Buzzer error	<p>Check if the buzzer cable is correctly connected (See "Wiring" above).</p>
Back Lit Error	<p>Check that the LED cable is correctly connected (See "Wiring" above).</p> <p>Use Default Configuration Card to set it back to normal.</p>
Keypad No Response	<p>Power off reader for 5 seconds and power on again</p>

WARRANTY

The warranty period of Transmitter Solutions keypads are 24 months. This warranty shall begin on the date the keypad is manufactured. During the warranty period, the product will be repaired or replaced (at the sole discretion of Transmitter Solutions) if the product does not operate correctly due to a defective component. This warranty does not extend to (a) the product case, which can be damaged by conditions outside the control of Transmitter Solutions, or (b) battery life of the product. This warranty is further limited by the following disclaimer of warranty and liability:

EXCEPT AS SET FORTH ABOVE, TRANSMITTER SOLUTIONS MAKES NO WARRANTIES REGARDING THE GOODS, EXPRESS OR IMPLIED, INCLUDING WARRANTY OF MERCHANTABILITY OR WARRANTY OF FITNESS FOR A PARTICULAR PURPOSE. BUYER MAKES NO RELIANCE ON ANY REPRESENTATION OF TRANSMITTER SOLUTIONS, EXPRESS OR IMPLIED, WITH REGARD TO THE GOODS AND ACCEPTS THEM "AS-IS/WHERE-IS". TRANSMITTER SOLUTIONS SELLS THE GOODS TO BUYER ON CONDITION THAT TRANSMITTER SOLUTIONS WILL HAVE NO LIABILITY OF ANY KIND AS A RESULT OF THE SALE. BUYER AGREES THAT TRANSMITTER SOLUTIONS SHALL HAVE NO LIABILITY FOR DAMAGES OF ANY KIND, WHETHER DIRECT, INCIDENTAL OR CONSEQUENTIAL DAMAGES, INCLUDING INJURIES TO PERSONS OR PROPERTY, TO BUYER, ITS EMPLOYEES OR AGENTS, AS A RESULT OF THE SALE. BUYER ALSO AGREES TO HOLD TRANSMITTER SOLUTIONS HARMLESS FROM ANY CLAIMS BUYER, OR ANY THIRD PARTY, MAY HAVE AS A RESULT OF BUYER'S USE OR DISPOSAL OF THE GOODS. BUYER HAS READ THIS DISCLAIMER AND AGREES WITH ITS TERMS IN CONSIDERATION OF RECEIVING THE GOODS.



2480 South 3850 West, Suite B Salt Lake City, UT 84120
(866) 975-0101 • (866) 975-0404 fax
www.transmittersolutions.com