

OPERATING INSTRUCTIONS

NIR-50TM

RETROREFLECTIVE PHOTOEYE

UL 325 NON-COMPLIANT



4564 Johnston Parkway, Cleveland, Ohio 44128

P. 800 426 9912 F. 216 518 9884

Sales Inquiries: salesupport@emxinc.com

Technical Support: technical@emxinc.com

www.emxinc.com

Cautions and Warnings	2
Product Overview	2
Specifications	2
Controls and Indicators	3
Connections	3
Troubleshooting	4
Installation	4
Ordering Information	4

Cautions and Warnings

WARNING ... Not to be used for Personnel Protection



Never use product as sensing devices for personnel protection. Doing so could cause serious injury or death. These sensors do **NOT** include the self-checking redundant circuitry necessary to allow their use in personnel safety applications. A sensor failure or malfunction can cause either an energized or de-energized sensor output condition. UL 325 Non-compliant.

Retroreflective photoeyes rely on a reflective surface (a reflector) for proper operation. In some cases a vehicle with reflective surface at a given distance can act as a reflector and allow the gate to close on a car.

EMX Industries Inc. assumes no responsibility in this case and all risk is on the installer, designer and user of the gate system with a retroreflective photoeye. In case such risk is not acceptable, EMX Industries Inc. strongly recommends the use of a through beam type of photoeye.

Product Overview

Product may be used for activation of gates or doors when the beam is interrupted. The NIR-50 fail-safe reflective sensor uses an infrared signal that is returned from a reflector mounted on the opposite side of the opening to be monitored.

Specifications

Specifications	
Power Supply	12 – 240VDC / 24 – 240VAC
Power Supply Tolerance	+ / - 10%
Current Draw	28mA standby 15mA detected @ 12 VDC
Housing Material	ABS and Acrylate on lenses
Relay Type	SPDT 2A @ 24 VDC 0.6A @ 220 VAC
Temperature Range	-20° - +60°C
Connector	Cable 2 Meters (6feet)
Environmental Protection	IP 66 IEC
Size	1.6" x 2.6" x 0.8"
Response time	10ms maximum
Range	0.3 – 30 feet
Certifications	CE

Controls and Indicators

Sensitivity

Clockwise increases sensitivity

Normally set to maximum (single turn)

Yellow LED

LED is on when unit is energized and signal is stable

Red LED

Is on when is energized and alignment is correct

LED is off when unit is energized and object is detected or not aligned

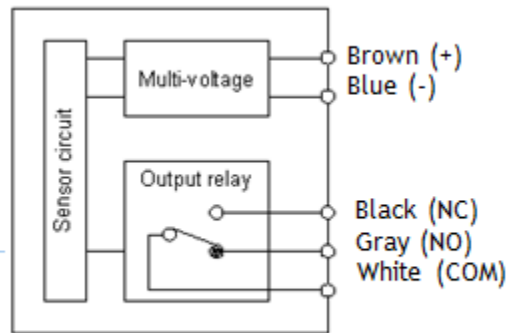

Shown energized and aligned

Connections

Wire Color	Connection
Brown	Power Positive (+)
Blue	Power Negative (-)
Black	Internal Relay Contact Normally Closed (NC)
Gray	Internal Relay Contact Normally Open (NO)
White	Internal Relay Contact Common (COM)

Troubleshooting

Symptom	Possible cause	Solution
Units stays in detect	Unit out of alignment	Verify alignment
	Reflector covered with dirt, dust, snow, or water	Clean reflector surface of contaminants
	Water inside of reflector	Replace reflector Add Reflector O-HD
No Output	No power	Check wiring as per chart on page 2
	Bad Connection, wires broken	Check connections
	Mis-wired	Verify wired to correct inputs on operator
No Detection	Unit not powered	Check Power
	Other reflective surface causing signal return	Check surrounding area for reflective surface

Installation

Recommended alignment technique is to mount the NIR-50 at the desired location and hold reflector about 2 or 3 feet in front of the unit and while watching the lights to assure that both remain lit, move backward to the desired mounting location for the reflector. You may have to move the reflector up, down, left or right to keep the reflector in the middle of the signal path. This assures the least troublesome set up by keeping the reflector off the edges of the signal where any movement may take it out of alignment. Note: the signal pattern is only 2 feet diameter.

Ordering Information

NIR-50	Retroreflective photoeye, includes mounting bracket with hardware
NIR-HD	Steel protective hood
Reflector -O	Plastic reflector, 3" dia.
Reflector-O-HD	Plastic hood for reflector

Accessories

NIR-HD



Reflector-O



Reflector-O-HD



Warranty

EMX Industries Incorporated warrants all products to be free of defects in materials and workmanship for a period of two years under normal use and service from the date of sale to our customer. This warranty does not cover normal wear and tear, abuse, misuse, overloading, altered products, damage caused by incorrect connections, lightning damage, or use other than intended design.

There is no warranty of merchantability. There are no warranties expressed or implied or any affirmation of fact or representation except as set forth herein.

EMX Industries Inc. sole responsibility and liability, and the purchaser's exclusive remedy shall be limited to the repair or replacement at EMX Industries option of a part or parts found not conforming to the warranty. In no event shall EMX Industries Inc. be liable for damages, including but not limited to damages resulting from non-conformity, defect in material or workmanship.

Effective date: January 1st, 2002



BLANK PAGE



4564 Johnston Parkway
Cleveland, Ohio 44128
United States of America
www.emxinc.com

Technical Support: (216) 834-0761
technical@emxinc.com

Sales: (216) 518-9888
Fax: (216) 518-9884
salesupport@emxinc.com



Revision 1.5
6.15.2018