

MONARCH 295SEPA1K

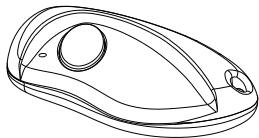

Manual

**Transmitter
Solutions**

Monarch

*Thank you for choosing a Transmitter Solutions product .
Please read this manual carefully before using the product.*

Made in Italy. Copyright © 2006 by Transmitter Solutions

CONTENTS

1 - TRANSMITTER OVERVIEW

- 1A - General information
- 1B - Technical specifications
- 1C - Main components

2 - NUMBERING

3 - PROGRAMMING

4 - OPERATION

5 - BATTERY ACCESS

6 - TROUBLESHOOTING

1A - General information

The Transmitter Solutions - Monarch 295SEPA1K transmitter is a key chain style mini transmitter operating at 295 MHz. It has been designed for use with programmable telephone entry, security, and access control systems operating with a 295 MHz frequency receiver.

The protocol is AUTOkey compatible and the code sent by the transmitter includes a 24 bit security code which allows up to 16,777,216 code combinations.

The Transmitter Solutions - 295R receiver which operates with this transmitter has a Wiegand 33 bit and can operate any type of access control system equipped with the same protocol. The CR 2016 lithium batteries of the transmitter have a shelf life of about 6 months. The product fully complies with Part 15 of FCC Regulations and the European Directives 99/5/CE, 89/336/CEE, 73/23/CEE.

1B - Technical specifications

Operating frequency	295 MHz
Number of keys:	1
Battery :	2 x 3V lithium batteries CR2016
Battery life:	18 ÷ 24 months
Number combinations :	16,777,216
Protocol :	AUTOkey compatible
Operating temperature:	-20°F ÷ +131°F (-20°C ÷ +55°C)
Overall dimensions:	2.4"x1.4"x0.51" (61x36x13 mm)
Weight:	0.49 oz. (14 gr.)

1C - Main components

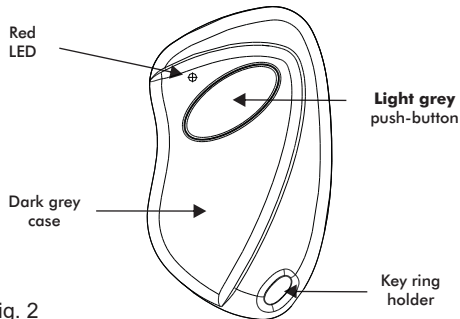

Fig. 2

2 - NUMBERING

Each transmitter is manufactured and sold with a different factory-set serial number.

3 - PROGRAMMING

The transmitter must be programmed into your system memory. Your own installer or reseller will provide you the necessary instructions for your system.

4 - OPERATION

A - Firmly depress the button until the small red LED illuminates.
B - After the LED has illuminated, release the button.
If the device you are attempting to activate does not respond, repeat steps A and B or consult section 6 (Troubleshooting) of this manual.

5 - BATTERY ACCESS

To access the battery open the case with a screwdriver acting on the slot between the cover and the bottom and remove the bottom, as shown in fig. 3a and 3b. Slide out the old batteries and replace them with the new ones [CR2016] respecting the polarity, with the positive (+) side upward.
NOTE: Please dispose of the batteries properly according to local laws and regulations.

Test proper battery installation by verifying that the red LED illuminates when the button is pushed.

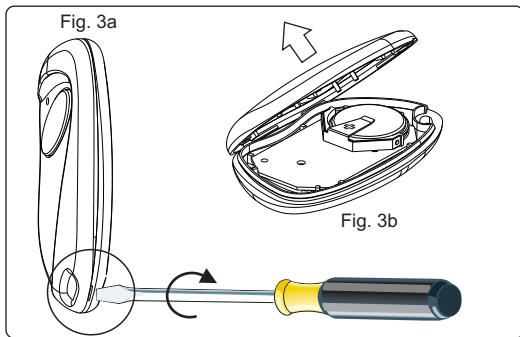

6 - TROUBLESHOOTING

PROBLEM	SOLUTION
The system does not receive the transmitter signal. The transmitter LED will not light	Replace the transmitter batteries
The system does not receive the transmitter signal. The transmitter LED is ON	Check to verify the transmitter is programmed into your system
The operating range is reduced	Replace the transmitter batteries

Transmitter Solutions - Type : 295SEPA1K

FCC ID : SU7295SEPC1K

This device complies with Part. 15 of the FCC Rules
Operation is subject to the following two conditions:
(1) This device may not cause harmful interference, and
(2) this device must accept interference received, including interference that may cause undesired operation.

Notice

Any changes or modification to Transmitter Solutions equipment not expressly approved by Transmitter Solutions could void the manufacturer's warranty.

WARRANTY

The warranty period of Transmitter Solutions 295 transmitters is 24 months, beginning from the manufacturing date of the transmitter. During this period, if the product does operate correctly, due to a defective component, the product will be repaired or replaced at the sole discretion of Transmitter Solutions. The warranty does not extend to the transmitter case which can be damaged by conditions outside the control of Transmitter Solutions or to battery life.



TRANSMITTER SOLUTIONS
2505 Chandler Avenue, Suite, 1
Las Vegas, NV 89120 -
(866) 975-0101 - (866) 975-0404 Fax
sales@transmittersolutions.com