

# ***ICE-LOCK***

*GSM Code Lock access control unit*



***INSTALLATION MANUAL***

**Transmitter**  **SOLUTIONS**<sup>®</sup>

## Contents

<b>1</b>	<b>FOR YOUR SAFETY</b> .....	<b>5</b>
<b>2</b>	<b>INTRODUCTION</b> .....	<b>6</b>
<b>3</b>	<b>FEATURES AND APPLICATIONS</b> .....	<b>7</b>
<b>4</b>	<b>START UP</b> .....	<b>8</b>
<b>5</b>	<b>LED DISPLAY</b> .....	<b>9</b>
<b>6</b>	<b>CLEAR ALL PROGRAMMED DATA FROM SIM</b> .....	<b>10</b>
<b>7</b>	<b>CONNECTION DIAGRAM</b> .....	<b>11</b>
<b>8</b>	<b>PROGRAMMING ICE-LOCK</b> .....	<b>12</b>
<b>9</b>	<b>THE ICE-LOCK PARAMETERS</b> .....	<b>13</b>
9.1	ALARM SUPPORT .....	13
9.2	OUTPUT MANAGEMENT .....	16
9.3	DIRECT ACCESS BY ENTERING PIN ACCESS CODES VIA ILLUMINATED KEYPAD .....	17
9.4	SECURITY LEVEL - SL .....	19
9.5	PREPAID CARD CREDIT AND VALIDITY INFORMATION .....	20
9.6	SET-UP PARAMETERS .....	22
9.7	SMS MESSAGES EDITOR.....	25
9.8	CLIP .....	26
9.9	SPECIAL SMS COMMANDS .....	28
<b>10</b>	<b>PRINT-OUT OF THE PARAMETERS</b> .....	<b>30</b>
10.1	RECEIVE ALL PARAMETERS (PALL).....	30
10.2	CHECK SW REVISION (PSW) .....	30
10.3	CHECK SIGNAL QUALITY (PSQ) .....	30
10.4	RECEIVE TELEPHONE NUMBERS (PTN) .....	30
10.5	RECEIVE LINKS (PLN) .....	30
10.6	RECEIVE INPUT PARAMETERS (PIN).....	31
10.7	RECEIVE INPUT FILTER VALUE (PID).....	31
10.8	RECEIVE OUTPUT FILTER VALUE (POD) .....	31
10.9	RECEIVE DELAY BEFORE DIAL VALUE (PDD).....	31
10.10	RECEIVE ACCESS TELEPHONE NUMBERS (PSL) .....	31
10.11	RECEIVE OUTPUT PARAMETERS (POS) .....	31
10.12	RECEIVE ALL PROGRAMMED SMS MESSAGES (P#) .....	32
10.13	RECEIVE SET UP PARAMETERS VALUE (PPA) .....	32
10.14	RECEIVE CREDIT PARS PARAMETERS (PCREF) .....	32
10.15	RECEIVE CREDIT CHECK TELEPHONE NUMBERS (PCN) .....	32
10.16	RECEIVE ALL CLIP PARAMETERS (PCLP) .....	32

10.17	RECEIVE STATE OF THE CREDIT FOR THE PREPAID CARD .....	33
10.18	RECEIVE STATE OF THE OUTPUTS (PORC) .....	33
10.19	MANUAL GSM MODULE RESTART (MRES).....	33
10.20	RECEIVE STATUS OF INPUTS (INS) .....	33
10.21	RECEIVE PIN ACCESS CODES PARAMETERS (PPIN).....	33
10.22	RECEIVE ICE-LOCK LOG .....	34
<b>11</b>	<b>CHANGING PARAMETERS USING THE SMS COMMANDS.....</b>	<b>35</b>
<b>12</b>	<b>DEFAULT SETTINGS ON ICE-LOCK .....</b>	<b>37</b>
<b>13</b>	<b>PARAMETERS PRINT-OUT COMMANDS .....</b>	<b>39</b>
<b>14</b>	<b>TECHNICAL SPECIFICATIONS.....</b>	<b>40</b>

## Figures

---

Figure 1:	ICE-LOCK Connection diagram.....	11
Figure 2:	Input Connection diagram .....	14
Figure 3:	Output Connection diagram .....	16

## Tables

---

Table 1:	IN, ID and DD parameters .....	14
Table 2:	IN, ID, DD parameters example .....	14
Table 3:	Remote alarm reporting parameters.....	15
Table 4:	Remote alarm reporting example .....	16
Table 5:	Output management parameters .....	17
Table 6:	Output management parameters example .....	17
Table 7:	Entering PIN access code parameters .....	18
Table 8:	Entering PIN access codes example.....	18
Table 9:	SL parameter .....	19
Table 10:	SL example .....	19
Table 11:	Prepaid card validity parameters.....	21
Table 12:	Credit example .....	22
Table 13:	Set-up parameters .....	24
Table 14:	Set-up parameters example .....	24
Table 15:	Message parameters .....	25

Table 16: Message parameters example .....	25
Table 17: CLIP parameters .....	27
Table 18: CLIP parameters example .....	27
Table 19: LOG parameters .....	27
Table 20: LOG parameters example .....	28
Table 21: SMS commands. ....	29
Table 22: SMS commands example. ....	29
Table 23 ICE-LOCK default settings .....	38
Table 24: ICE-LOCK parameters print out commands .....	39

# 1 FOR YOUR SAFETY

---

Read these simple guidelines. Not following them may be dangerous or illegal. Read the complete user guide for further information.

## **SWITCH ON SAFELY**

Do not switch the unit on when use of wireless phone is prohibited or when it may cause interference or danger.

## **INTERFERENCE**

All wireless phones and units may be susceptible to interference, which could affect performance.

## **SWITCH OFF IN HOSPITALS**

Follow any restrictions. Switch the unit off near medical equipment.

## **SWITCH OFF IN AIRCRAFT**

Follow any restrictions. Wireless devices can cause interference in aircraft.

## **SWITCH OFF WHEN REFUELING**

Do not use the unit at a refueling point. Do not use near fuel or chemicals.

## **SWITCH OFF NEAR BLASTING**

Follow any restrictions. Do not use the unit where blasting is in progress.

## **USE SENSIBLY**

Use only in the normal position as explained in the product documentation. Do not touch the antenna unnecessarily.

## 2 INTRODUCTION

---

ICE-LOCK is a universal remote controller based on GSM technology. It is designed as unlimited range, wire free, low cost, and highly robust remote control system.

As all other devices from portfolio, ICE-LOCK supports alarm detection, stay-alive messages, credit checking etc...

The ICE-LOCK is a GSM remote control unit with CodeLock keypad which can open automated electric gates. You can dial the number of the ICE-LOCK unit free of charge (Caller ID) or type your unique entry code into CodeLock keypad. When the call is received or the correct code is recognized, the ICE-LOCK unit opens the gates.

Changing the phone numbers, setting the codes can be programmed by sending simple SMS to the unit or via WEB (Option on special request).

Typical use of the ICE-LOCK: rental apartments, holiday houses, restricted access areas, storages, laboratories, etc.

ICE-LOCK is equipped with relay output.

## 3 FEATURES AND APPLICATIONS

---

### Features:

- ⇒ Built-in 2 or 4 band GSM module
- ⇒ **Up to 50 PIN access codes (4 digit)**
- ⇒ 1 alarm input
- ⇒ 1 output (relay supported)
- ⇒ Up to 50 telephone numbers for CLIP support
- ⇒ Programming by USB on the ICE-LOCK
- ⇒ Programming by SMS command – all parameters including the PIN access codes
- ⇒ Anti-tampering input

### Applications:

- ⇒ Free of charge access control by typing 4 digit PIN access code on the keypad
- ⇒ Free of charge remote control (CLIP)
- ⇒ Simple alarm support

## 4 START UP

---

⇒ Insert SIM card to be used for ICE-LOCK in your personal mobile phone.

**IMPORTANT**

**ERASE THE PIN CODE ON THE SIM CARD!**

- ⇒ Insert SIM card in ICE-LOCK device.  
The unit must be switched OFF when you insert the SIM!
- ⇒ Connect the external antenna to antenna connector.
- ⇒ Connect input and output to ICE-LOCK.
- ⇒ Connect power cable to ICE-LOCK device
- ⇒ Connect device to source power supply voltage.
- ⇒ Wait until LED1 (green) starts flashing. This is set in around 30 seconds.
- ⇒ ICE-LOCK unit is now ready to operate.

**IMPORTANT**

Before sending any SMS commands to ICE-LOCK device, device must be powered ON and in normal operation!



## 5 LED DISPLAY

---

### Green LED (LED1)

- Indicates the level of the GSM signal from 1 to 5 LED flashes (1 is weak signal, 5 is excellent signal)

### Yellow LED (LED2)

- Short flashing indicates that the GSM module is ON, but it is not yet connected on the GSM network. After connection, yellow led is flashing with short pulse (0,5s) ON and a long pulse OFF (5s).

## 6 CLEAR ALL PROGRAMMED DATA FROM SIM

---

This is highly recommended when a SIM card you are going to use for the ICE-LOCK is not new and it already has some data stored in the phone book memory.

By sending this SMS to ICE-LOCK all programmed parameters and numbers are cleared:

**;SDCLR;**

After the command is received by the device all configuration parameters on the SIM card including the SMS are deleted. The procedure can take up-to 2 minutes, depends on the version of the SIM card.

The ICE-LOCK will restart after the configuration is deleted.

**NOTE**

By sending this command to the ICE-LOCK ALL DATA are erased from the SIM card, including SMS!

## 7 CONNECTION DIAGRAM

Before connecting the ICE-LOCK please take a look at connection diagram very carefully.

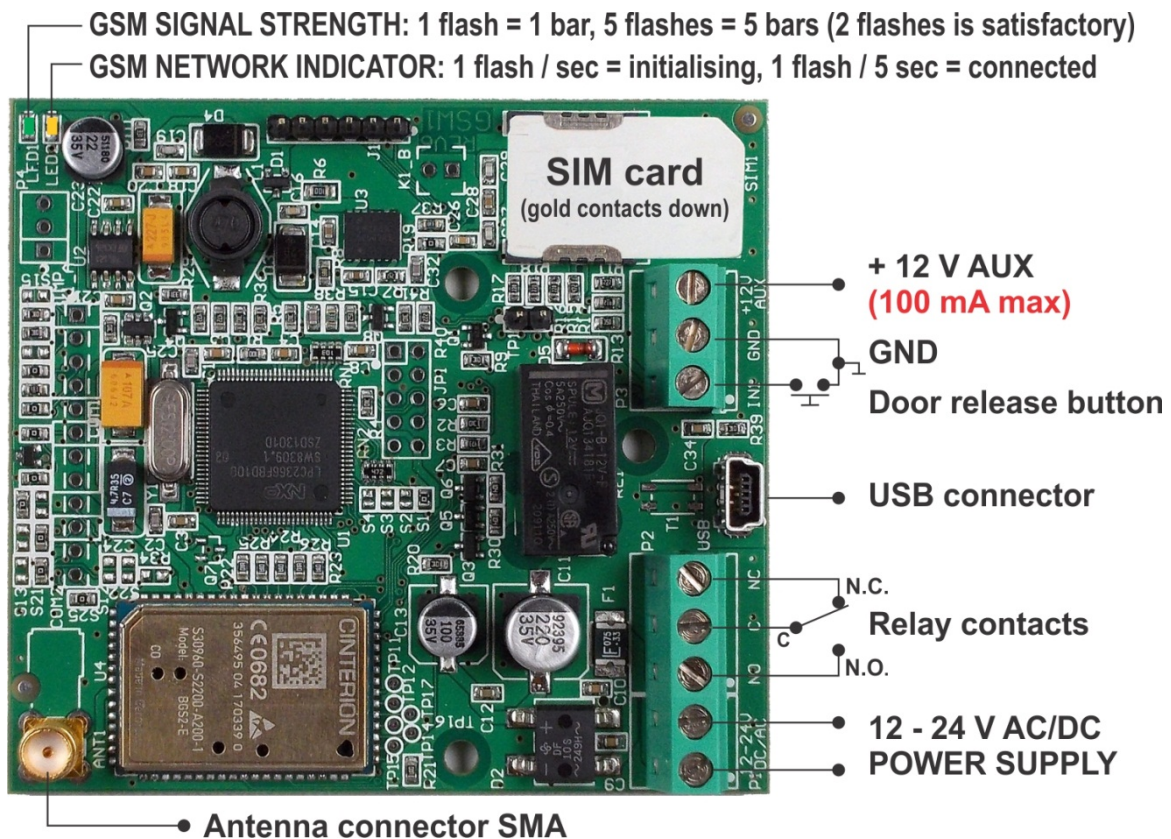

Figure 1: ICE-LOCK Connection diagram

**VERY  
IMPORTANT**

**Do not use the +12V AUX power output for electric lock driving!**  
**You can use it to power external sensors only (100mA max)!**  
**Use separate power source for door electric lock!**

## 8 PROGRAMMING ICE-LOCK

---

ICE-LOCK device supports different types of programming:

- ⇒ You can program ICE-LOCK remotely by SMS command. You can program all parameters including the PIN access codes (PINx parameters).
- ⇒ You can program ICE-LOCK directly with the use of USB connection on the device. You can program all parameters except PIN access codes. Programming of PIN access codes is not supported yet on EasySet SW, you can program them by sending simple SMS message to the unit. If there is no CD with the program and drivers in your package, please contact your reseller to receive the application running on PC for management of the ICE-LOCK and the appropriate USB drivers.

## 9 THE ICE-LOCK PARAMETERS

To support versatile functionality of ICE-LOCK different parameters are used. The parameters are divided in logical sections and are described in the following chapters.

### 9.1 ALARM SUPPORT

Alarm reporting is supported by group of different parameters. First section is used to define the relations needed for alarm to be triggered. The second section is used to report alarm.

#### 9.1.1 ALARM TRIGGERING

Parameters are used to control (filter) the triggering of the alarm inputs.

##### 9.1.1.1 IN parameters

Alarm and reset input can be triggered in 4 different ways. The status of the input can either be normal closed (N.C) or normal open (N.O.) with positive (+ 12V) or negative (GND) voltage.

Activation of the input/alarm is reported by IN1 values 0 to 2. If the user needs to receive information of the input/alarm restores use IN1 values 4 to 6. IN1 value 3 disables the input/alarm reporting.

- ⇒ IN = 0 – Normal Open – triggered with negative voltage (GND)
- ⇒ IN = 1 – Normal Close – breaking negative or positive voltage loop
- ⇒ IN = 2 – Normal Open – triggered with positive voltage (+ 12VCC)
- ⇒ IN = 3 – Not in use
- ⇒ IN = 4 ⇒ IN = 0 + input reset SMS
- ⇒ IN = 5 ⇒ IN = 1 + input reset SMS
- ⇒ IN = 6 ⇒ IN = 2 + input reset SMS

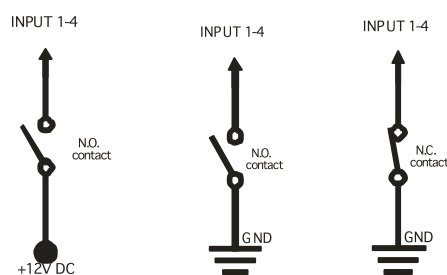

Figure 2: Input Connection diagram

### 9.1.1.2 ID parameters

ID parameter determines time period of the pulse length to trigger the alarm. The pulse time can be from 0,5 seconds to 9999 seconds. The default time is 0,5 seconds when the parameter value is 0.

Parameter is in seconds.

### 9.1.1.3 DD parameters

This parameter is used to define the delay between the time that alarm input is triggered and the time that alarm is reported.

Parameter is in seconds.

### 9.1.1.4 Table of parameters

Name	Comment
IN1	Mode of operation for input 1
ID1	Input time integration delay on input 1
DD1	Time delay for alarm reporting on input 1

Table 1: IN, ID and DD parameters

Example:

#### ◆ Direct programming on the SIM card

ICE-LOCK PROGRAMMING TABLE		
SIM CARD PHONE BOOK		
Name	Number	Description
IN1	0	Alarm activated by connecting to GND
ID1	10	Input 1 has to be valid for 10 second to trigger the alarm
DD1	15	Reporting of the alarm on input 1 is delayed by 15s

Table 2: IN, ID, DD parameters example

#### ◆ Remote programming by SMS

;IN1=0;ID1=10;DD1=15;

## 9.1.2 REMOTE REPORTING ALARM EVENTS

Parameters used to define the way to report the alarm event.

**NOTE** ICE-LOCK device send SMS messages for reporting alarm events.

### 9.1.2.1 TN parameters

Telephone numbers for remote alarm reporting are listed as TN parameters. Remote alarm reporting on ICE-LOCK is done via SMS messages.

### 9.1.2.2 LN parameters

This parameter is used to link alarm event from inputs or any other source to the telephone numbers on TN list.

### 9.1.2.3 Table of parameters

Name	Comment
TN1	1 <sup>st</sup> telephone number
TN2	2 <sup>nd</sup> telephone number
TN3	3 <sup>rd</sup> telephone number
TN4	4 <sup>th</sup> telephone number
TN5	5 <sup>th</sup> telephone number
LN1	Input & telephone No. linking for 1 <sup>st</sup> alarm input (TN1 – TN5)
LN3	Periodic test SMS. No. linking (TN1 – TN5)
LN4	SIM card refill. No. linking (TN1 – TN5)
LN5	NAC list. No. linking (TN1 – TN5) (see note)
LN6	Log status. No. linking (TN1 – TN5)

Table 3: Remote alarm reporting parameters

Example:

#### ◆ Direct programming on the SIM card

ICE-LOCK PROGRAMMING TABLE		
SIM CARD PHONE BOOK		
Name	Number	Description
TN1	042376678	1st telephone number
LN1	13	Input 1 reports alarm to TN1 & TN3
LN5	1	NAC event sent to TN1

Table 4: Remote alarm reporting example

- ◆ **Remote programming by SMS**  
;TN1=042376678;LN1=13;LN5=1;

**NOTE**

When telephone number (calling or messaging ICE-LOCK) is not authorized, not acknowledge event occurs (NAC). The telephone number responsible for this event can be send to TN user for notification.

## 9.2 OUTPUT MANAGEMENT

---

ICE-LOCK supports the possibility to report alarms from inputs and any other events locally via 1 output. The behavior is defined using next parameters

### 9.2.1 OS parameter

---

ICE-LOCK device has 1 dedicated relay supported outputs. Outputs can be configured to different behavior:

- ⇒ OSx = 0 - Disabled
- ⇒ OSx = 1 - Bi-stable toggle mode
- ⇒ OSx = yyy - Mono-stable pulse mode (duration in seconds)

Typical connection for the output:

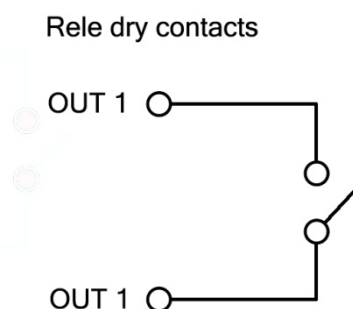

Figure 3: Output Connection diagram

### 9.2.2 OD parameter

---

OD parameter is used to link the alarm event directly to output. Direct linking can be done on input alarm events and some other internal events.



### 9.2.3 OP parameter

---

OP parameter is used to invert the polarity of the outputs.

- ⇒ 0 – normal
- ⇒ 1 – inverted

### 9.2.4 Table of parameters

---

Name	Comment
OS1	Mode of operation for output 1
OD1	Input 1 direct link to outputs
OD3	GSM network problem direct link to outputs
OD4	NAC direct link to outputs
OP1	Invert control for output 1

Table 5: Output management parameters

Example:

#### ◆ Direct programming on the SIM card

ICE-LOCK PROGRAMMING TABLE		
SIM CARD PHONE BOOK		
Name	Number	Description
OS1	14	Mono-stable pulse mode (14s pulse)
OD1	1	Input 1 activates output 1
OP1	1	Output 1 inverted

Table 6: Output management parameters example

#### ◆ Remote programming by SMS ;OS1=14;OD1=1;OP1=1;

## 9.3 DIRECT ACCESS BY ENTERING PIN ACCESS CODES VIA ILLUMINATED KEYPAD

---

The user may control the predefined output by entering the PIN access codes. PIN access code from 1 to 50 (PIN1 to PIN50) will activate the Output.

### 9.3.1 PIN1 to PIN50

---

PINx parameters are the PIN access codes for controlling the output.

### 9.3.2 Table of parameters

Name	Comment
PIN1	PIN access code 1.
PIN2	PIN access code 2.
PIN3	PIN access code 3.
...	
PIN48	PIN access code 48.
PIN49	PIN access code 49.
PIN50	PIN access code 50.

Table 7: Entering PIN access code parameters

Example:

#### ◆ Direct programming on the SIM card

ICE-LOCK PROGRAMMING TABLE		
SIM CARD PHONE BOOK		
Name	Number	Description
PIN1	3369	PIN access code 1.
PIN12	1234	PIN access code 12.

Table 8: Entering PIN access codes example

#### ◆ Remote programming by SMS

;PIN1=3369;PIN12=1234;

#### NOTE

PINx access codes must be 4 digits long, and must start with number greater or equal 1.

### 9.3.3 Using the keypad for activating the Output – opening the doors

The user **presses the 4 digit PIN access code** and then **presses the '#' key** on the keypad to confirm the entry. If the code is correct, the output relay is activated which triggers the electric lock, ramp, bollard, sliding doors, etc...

Example:

#### ◆ Typing the PIN access code on the keypad

For PIN1 type **3369** and press **'#'**. If the code is correct you will hear long beep confirmation, if the PIN access code is incorrect you will hear 3 short beeps.

## 9.4 SECURITY LEVEL - SL

SL parameter from 0 to 5 defines which telephone number stored in the phone book from TN1 – TN5 can enter into programming and remote control of the ICE-LOCK (dialing the ICE-LOCK phone number or sending the SMS).

### NOTE

When the SL level is 0, an access to the ICE-LOCK is possible from any phone!

### IMPORTANT

Before any SL number is programmed the ICE-LOCK can accept ALL CALLS. Remote SMS programming and remote controlling is possible from any phone!

Name / value	Comment
SL = 0	All calls and SMS are accepted
SL = 1	Only number stored under parameter TN1 has access to unit
SL = 2	Numbers stored under parameters TN1 to TN2 have access to unit
SL = 3	Numbers stored under parameters TN1 to TN3 have access to unit
SL = 4	Numbers stored under parameters TN1 to TN4 have access to unit
SL = 5	Numbers stored under parameters TN1 to TN5 have access to unit

Table 9: SL parameter

Example:

### ◆ Direct programming on the SIM card

ICE-LOCK PROGRAMMING TABLE		
SIM CARD PHONE BOOK		
Name	Number	Description
SL	3	No. stored under parameters TN1 to TN3 have access to unit

Table 10: SL example

- ◆ Remote programming by SMS  
;SL=3;

## 9.5 PREPAID CARD CREDIT AND VALIDITY INFORMATION

ICE-LOCK can be used with prepaid SIM cards and its limitations. To be able to overcome this limitation of the prepaid SIM cards, ICE-LOCK offers the possibility of automatic checking mechanism for credit and time expiration.

**NOTE**

ICE-LOCK automatically sends warning SMS when the credit reaches low level defined by LCV parameter or SIM card validity is near to expiration.

**NOTE**

For support of different GSM providers contact support.

### 9.5.1 Programming prepaid card credit and validity string

To be able to support credit and time validity checking different parameters are used.

#### 9.5.1.1 LCV and SCV parameter

LCV is used to set the limit for low credit event. If the credit on prepaid SIM cards falls below this limit SMS is send.

SCV the period of valid operating time varies with different GSM network providers. The value can be programmed from 1 to 360 days. The default value does not presume any kind of expiry warning.

For example in Slovenia SCV are 90 and in Italy 360 days

### 9.5.1.2 CC1, CC2 and CC3 parameters

---

Number used to check low credit value. They are provided from the GSM providers.

- ⇒ CC1 - This method can be used by any GSM provider that supports Unstructured Supplementary Service Data
- ⇒ CC2 - This method is dedicated to Italian TIM mobile provider
- ⇒ CC3 - This method is dedicated to Italian Vodafone mobile provider

### 9.5.1.3 CREF, CTIM, CVODA parameters

---

Parameters are used to find the credit value of the prepaid SIM card. Strings under these parameters are used to parse the replay message from the GSM provider.

- ⇒ CREF - Parse string for the replays received from CC1 number
- ⇒ CVODA - Parse string for the replays received from CC2 number
- ⇒ CTIM - Parse string for the replays received from CC3 number

### 9.5.1.4 Table of parameters

---

Name	Comment
LCV	Low credit value, bottom limit for low credit event.
SCV	SIM card validity time (in days)
CC1	Credit number for credit check universally used
CC2	Credit number for credit check dedicated for Italian TIM mobile provider
CC3	Credit number for credit check dedicated for Italian Vodafone mobile provider
CREF	String for parsing replay message from CC1 number
CVODA	String for parsing replay message from CC2 number
CTIM	String for parsing replay message from CC3 number

Table 11: Prepaid card validity parameters

Example:

◆ Direct programming on the SIM card

ICE-LOCK PROGRAMMING TABLE		
SIM CARD PHONE BOOK		
Name	Number	Description
CC1	*448#	Si.mobil
CC2	4916	TIM Italy
CC3	404	Vodafone Italy
LCV	4	Low credit message will be send bellow 4

Table 12: Credit example

◆ Remote programming by SMS

;CC1=\*448#;CC2=4916;CC3=404;LCV=4;

## 9.6 SET-UP PARAMETERS

---

Different parameters are used to support versatile functionality of ICE-LOCK.

### 9.6.1 UDC parameter

---

Parameter is used to synchronise ICE-LOCK clock to GSM network clock. User must enter the number of the ICE-LOCK SIM card (telephone number of ICE-LOCK device).

### 9.6.2 TST parameter

---

A test SMS is sent periodically. ICE-LOCK can send the test message in the interval ranging from 1 hour to 8760 hours.

Example:

To send test SMS TST value is set to 12, the numbers linked to “LN5” receive a test message every 12 hours.

### 9.6.3 MNF parameter

---

When it is necessary to fix the GSM network to one provider the user can use the MNF parameter. The MNF parameter switches automatic network searching to manual.

Example:

MCC/MNC code for Simobil is 29340, Mobitel is 29341, TIM is 22201, and Vodafone

Italy is 22210.

More information about national MCC/MNC codes can be acquired at:

[http://en.wikipedia.org/wiki/Mobile\\_Network\\_Code](http://en.wikipedia.org/wiki/Mobile_Network_Code)

### 9.6.4 ARST parameter

---

ARST parameter defines periodic of auto restart time (in hours) of the ICE-LOCK device.

### 9.6.5 ADF parameter

---

Parameter is used to define voice refresh function, to prevent blocking of SIM in some GSM networks.

**NOTE**

If this function is enabled ICE-LOCK device will make voice call to TN1 number.

### 9.6.6 LNG parameter

---

LNG parameter switches between the preprogrammed languages:

- ⇒ 0 - English
- ⇒ 1 - Italian
- ⇒ 2 - Slovenian
- ⇒ 3 - Croatian
- ⇒ 4 - Dutch
- ⇒ 5 - German
- ⇒ 6 - Spanish

### 9.6.7 BUZ parameter

Parameter is used to control buzzer functionality on ICE-LOCK. Buzzer is used to audio support some events on ICE-LOCK like pressing the keypad buttons, confirmation of correct PIN access code, warning beeps when incorrect PIN access code is entered, etc.

### 9.6.8 Table of parameters

Name	Comment
UDC	Tel. number of ICE-LOCK device
RAN	Auto answer ring number
TST	SMS test time out
MNF	Manual GSM provider selection
ARST	Time out control for automatic system restart
ADF	Auto dial functionality (Call TN1)
LNG	Language selection
BUZ	Buzzer control

Table 13: Set-up parameters

Example:

#### ◆ Direct programming on the SIM card

ICE-LOCK PROGRAMMING TABLE		
SIM CARD PHONE BOOK		
Name	Number	Description
MNF	29340	Manual fixing of the GSM provider (Simobil)
LNG	1	Switch on Italian language
ADF	90	Make voice call every 90 days
TST	24	24 hours periodic test SMS
BUZ	0	Mute buzzer

Table 14: Set-up parameters example

#### ◆ Remote programming by SMS

;MFN=29340;LNG=1;ADF=90;TST=24;BUZ=0;



## 9.7 SMS MESSAGES EDITOR

You can write and send a short SMS message for each alarm input. The default message is English, but it is possible to change language with LNG parameter. Each message is built from 3 parts and user can write the first (User Location) and the second (alarm event) part of the message. Unit adds the third part (alarm event description) automatically. Language of the 3rd part may be changed by LNG parameter. The message is stored in the SIM phone book so you should add any number for correct operation.

1	2	3	4	5	6	7	8	9	10	11	12	13	14	15	16
#	0	U	S	E	R		L	O	C	A	T	I	O	N	
#	1	I	N	P	U	T		1							

### NOTE

Message should not be longer than 14 characters! Space is also counted as one character!

### 9.7.1 Table of parameters

Name	Comment
#0	User location, same for all alarm messages
#1	Input 1, second part of message

Table 15: Message parameters

Example:

#### ◆ Direct programming on the SIM card

ICE-LOCK PROGRAMMING TABLE		
SIM CARD PHONE BOOK		
Name	Number	Description
#0House	1	Location definition
#1Kitchen	1	Alarm input is from the kitchen

Table 16: Message parameters example

- ◆ Remote programming by SMS  
;#0HOUSE=1;#1KITCHEN=1;

## 9.8 CLIP

---

CLIP is used to provide the “free of charge” options to control the outputs.

### 9.8.1 CLPEN parameter

---

Parameter used to enable CLIP functionality.

### 9.8.2 CLPOU parameter

---

Parameter used to choose which output will be controlled by the CLIP functionality.

### 9.8.3 CLPI parameter

---

This parameter, if set, is a precondition for CLIP function to control the output. The input define by the CLPI parameter must be active for CLIP function to control the output.

### 9.8.4 CLP1 ... CLP50 parameter

---

Set of telephone number, which can control the output. The number not on CLP list is not able to control the output using clip functionality.

### 9.8.5 Table of parameters

---

Name	Comment
CLPEN	Enable CLIP functionality
CLPOU	Control output pin when CLIP event

CLPI	CLIP input activation condition
CLP1	CLIP number 1
.	.
.	.
.	.
CLP50	CLIP number 50

Table 17: CLIP parameters

Example:

◆ Direct programming on the SIM card

ICE-LOCK PROGRAMMING TABLE		
SIM CARD PHONE BOOK		
Name	Number	Description
CLPEN	1	Enable CLIP functionality
CLPOU	2	CLIP control output 2
CLPI	0	No input activation condition
CLP1	040414414	CLIP number 1
CLP2	042340880	CLIP number 2

Table 18: CLIP parameters example

◆ Remote programming by SMS

;CLPEN=1;CLPOU=2;CLPI=0;CLP1=040414414;CLP2=042340880;

## 9.8.6 Table of parameters

---

Name	Comment
LOGN	Number of log events for printing out
LOGI	Log interface
ALC	Automatic log clear

Table 19: LOG parameters

Example:

### ◆ Direct programming on the SIM card

ICE-LOCK PROGRAMMING TABLE		
SIM CARD PHONE BOOK		
Name	Number	Description
LOGN	5	5 log events will be printed out on PLOG command
LOGI	0	Nonvolatile memory on ICE-LOCK
ALC	1	Log is auto cleared when full

Table 20: LOG parameters example

### ◆ Remote programming by SMS ;LOGN=5;LOGI=0;ALC=1;

## 9.9 SPECIAL SMS COMMANDS

---

These commands can only be issued only over SMS message, and are used to control some special functions of ICE-LOCK device.

### 9.9.1 ORC command

---

Command is used to control outputs directly via SMS message

### 9.9.2 SDCLR command

---

To clear all data on SIM card SDCLR command is used.

### 9.9.3 LCRL command

---

Command clears log on ICE-LOCK device.

### 9.9.4 CLPCLR command

---

Command is used to delete all CLP numbers.

### 9.9.5 MRES command

---

Command is used to manually restart GSM module on ICE-LOCK device.

### 9.9.6 SSRES command

---

Command is used to manually restart ICE-LOCK device.

### 9.9.7 Table of parameters

---

Name	Comment
ORC1	Control of output 1
SDCLR	Delete all SIM content
LCRL	Delete log on ICE-LOCK device
MRES	Manual reset of GSM module
SSRES	Manual reset of ICE-LOCK device

Table 21: SMS commands.

Example:

#### ◆ Remote programming by SMS

SMS command	Description
;ORC1=1; or ;ORC1=ON;	Activate output 1
;ORC1=0; or ;ORC1=OFF;	Deactivate output 1
;SDCLR;	Clear all data on SIM
;LCLR;	Delete log on ICE-LOCK device
;MRES;	Manual reset of GSM module
;SSRES;	Manual reset of ICE-LOCK device

Table 22: SMS commands example.

## 10 PRINT-OUT OF THE PARAMETERS

---

The user can check the settings of ALL parameters on the ICE-LOCK.

### 10.1 RECEIVE ALL PARAMETERS (PALL)

---

By sending this command to ICE-LOCK you receive SMS messages with all parameters that are currently programmed in the unit:

**;PALL;**

### 10.2 CHECK SW REVISION (PSW)

---

By sending this command to ICE-LOCK you receive SMS messages with current SW version running on ICE-LOCK device:

**;PSW;**

### 10.3 CHECK SIGNAL QUALITY (PSQ)

---

By sending this command to ICE-LOCK you receive SMS messages with signal quality when ICE-LOCK device is connected to network:

**;PSQ;**

### 10.4 RECEIVE TELEPHONE NUMBERS (PTN)

---

By sending this command to ICE-LOCK you receive SMS message with all currently programmed telephone numbers:

**;PTN;**

### 10.5 RECEIVE LINKS (PLN)

---

By sending this command to ICE-LOCK you receive SMS message with all currently programmed links:

**;PLN;**

## **10.6 RECEIVE INPUT PARAMETERS (PIN)**

---

By sending this command to ICE-LOCK you receive SMS message with all currently programmed Input parameters:

**;PIN;**

## **10.7 RECEIVE INPUT FILTER VALUE (PID)**

---

By sending this command to ICE-LOCK you receive SMS message with all currently programmed Input filters:

**;PID;**

## **10.8 RECEIVE OUTPUT FILTER VALUE (POD)**

---

By sending this command to ICE-LOCK you receive SMS message with all currently programmed direct output links:

**;POD;**

## **10.9 RECEIVE DELAY BEFORE DIAL VALUE (PDD)**

---

By sending this command to ICE-LOCK you receive SMS message with all currently programmed Input filters:

**;PDD;**

## **10.10 RECEIVE ACCESS TELEPHONE NUMBERS (PSL)**

---

By sending this command to ICE-LOCK you receive SMS message with programmed SL level:

**;PSL;**

## **10.11 RECEIVE OUTPUT PARAMETERS (POS)**

---

By sending this command to ICE-LOCK you receive SMS message with all currently programmed Outputs parameters:

**;POS;**

## 10.12 RECEIVE ALL PROGRAMMED SMS MESSAGES (P#)

---

By sending this command to ICE-LOCK you receive SMS message with all currently programmed alarm SMS messages:

**;P#;**

## 10.13 RECEIVE SET UP PARAMETERS VALUE (PPA)

---

By sending this command to ICE-LOCK you receive SMS message with all currently programmed Setup parameters:

**;PPA;**

## 10.14 RECEIVE CREDIT PARS PARAMETERS (PCREF)

---

By sending this command to ICE-LOCK you receive SMS message with all currently programmed credit parse parameters:

**;PCREF;**

## 10.15 RECEIVE CREDIT CHECK TELEPHONE NUMBERS (PCN)

---

By sending this command to ICE-LOCK you receive SMS message with programmed numbers for credit checking:

**;PCN;**

## 10.16 RECEIVE ALL CLIP PARAMETERS (PCLP)

---

By sending this command to ICE-LOCK you receive SMS message with all currently programmed CLIP functionality related parameters:

**;PCLP;**

**NOTE**

User can use ;PCLP=x,y; to limit the number of CLIP numbers to be printed.

x = start number

y = end number

Example

;PCLP=1,30; Prints first 30 CLIP numbers



## 10.17 RECEIVE STATE OF THE CREDIT FOR THE PREPAID CARD

---

By sending this command to ICE-LOCK you receive SMS message with Credit amount on your prepaid SIM card:

**;PCCX;**

Where X is the number of programmed prepaid card provider.

## 10.18 RECEIVE STATE OF THE OUTPUTS (PORC)

---

By sending this command to ICE-LOCK you receive SMS message with current outputs state.

**;PORC;**

## 10.19 MANUAL GSM MODULE RESTART (MRES)

---

By sending this command to ICE-LOCK shuts down GSM module and after a few second it switches the power of the GSM module ON again. The unit reboots all parameters from the SIM card.

**;MRES;**

## 10.20 RECEIVE STATUS OF INPUTS (INS)

---

By sending this command to ICE-LOCK you receive SMS message with current input state.

**;INS;**

## 10.21 RECEIVE PIN ACCESS CODES PARAMETERS (PPIN)

---

By sending this command to ICE-LOCK you receive SMS message with all currently programmed PIN access codes:

**;PPIN;**

Request a block of PIN codes: **;PPIN=1,5;** (access codes 1 – 5)

## 10.22 RECEIVE ICE-LOCK LOG

---

By sending this command to ICE-LOCK you receive SMS message with log on ICE-LOCK device.

**;PLOG;**

## 1 1 CHANGING PARAMETERS USING THE SMS COMMANDS

---

All programming parameters for ICE-LOCK can be changed by sending SMS commands.

Each SMS command should start and stop with semicolon (;).

If the confirmation SMS is needed, put “+” at the beginning of the SMS command:

ex.: ;+CLP1=09012345678;

The first SMS is SMS with telephone numbers (TN1 – TN5). If you would like to check which telephone numbers are programmed in ICE-LOCK please use the following command:

**;PTN;**

Return SMS is (example):

**;TN1=0;TN2=0;**

If you would like to enter telephone numbers in to ICE-LOCK you can use the following example:

**;TN1=040713470;TN2=+38643364850;**

If you would like to receive confirmation SMS write “+” before SMS command:

**++;TN1=040713470;TN2=+38643364850;**

Return SMS from ICE-LOCK is:

**;TN1=040713470;TN2=+38643364850;**

**NOTE**

You can use the same programming procedure for all parameters.

It is also possible to change different parameters with one SMS. Consider that the SMS message should not be longer than **160 characters** (included space characters).

If you would like to change the following parameters **TN1, IN1, OS1, ID1, LN1** and would like to receive confirmation SMS, try next example:

**++;TN1=+38640713470;IN1=1;OS1=15;ID1=120;LN1=1;**

Send SMS command to the ICE-LOCK and in a few seconds you will receive SMS message from it.

The sentence of the SMS must be the same as the one you have sent to the ICE-LOCK before.

## 1 2 DEFAULT SETTINGS ON ICE-LOCK

ICE-LOCK PROGRAMMING TABLE		
Name	Default Value	Short Description
TN1	Empty	Telephone number 1
TN2	Empty	Telephone number 2
TN3	Empty	Telephone number 3
TN4	Empty	Telephone number 4
TN5	Empty	Telephone number 5
IN1	0	Input 1 control
OS1	5	Output 1 mode
OD1	0	Input 1 direct output link
OD3	0	GSM network failure direct output link
OD4	0	NAC direct output link
LN1	Empty	Input 1, link to tel. numbers
LN3	Empty	Periodic SMS, link to tel. numbers
LN4	Empty	SIM card validity and credits status, link to tel. numbers
LN5	Empty	NAC, link to tel. numbers
LN6	Empty	LOG status, link to tel. numbers
ID1	0	Input 1 delay filter on input
DD1	0	Input 1 delay before dialing
RAN	0	Auto answer ring number
SL	0	Security level
#0	“User Location”	SMS main head text
#1	“Input1”	SMS input 1 text
CC1	Empty	Check credit Num 1
CC2	Empty	Check credit, TIM Italy
CC3	Empty	Check credit, Vodafone Italy
UDC	Empty	Tel. number of ZEUS4 device
SCV	0	SIM card time validity
TST	24	Periodic test SMS timeout
MNF	0	Network connection type
LCV	4	Low credit value
LNG	0	Language selection
LOT	60	Connection time out value
LOGN	5	Number of log events for printing out
LOGI	0	Log interface
ALC	1	Automatic log clear
ADF	90	Auto dial
ARST	0	Automatic reset timeout
OP1	0	Output 1 invert
BUZ	1	Buzzer function

ICE-LOCK PROGRAMMING TABLE		
Name	Default Value	Short Description
SPO	1	SIM card starting position
CREF	“EUR”	Parse text (contact support)
CTIM	“EURO”	Parse text (contact support)
CVODA	“DISPON. E.”	Parse text (contact support)
CLPEN	1	Enable CLIP functionality
CLPOU	1	Control output pin when CLIP event
CLPI	0	Clip input condition
CLPRI	0	Clip restore function
CLPRT	25	Clip restore function time out
CLP1	Empty	CLIP number 1
...	...	...
CLP50	Empty	CLIP number 50
PIN1	Empty	PIN access code 1
...	...	...
PIN50	Empty	PIN access code 50

Table 23 ICE-LOCK default settings

## 13 PARAMETERS PRINT-OUT COMMANDS

ICE-LOCK PRINT-OUT TABLE	
Name	Short Description
PALL	Prints all parameters available on ICE-LOCK.
PSW	Prints SW version of ICE-LOCK.
PSQ	Prints GSM network signal quality of ICE-LOCK.
PTN	Prints TNx numbers
PLN	Prints LNx links.
PIN	Prints INx parameters.
PID	Prints IDx parameters.
POD	Prints ODx parameters.
PDD	Prints DDx parameters
PSL	Prints SL parameter.
POS	Prints OSx parameters.
P#	Prints #x parameters.
PPA	Prints various setup parameters.
PCLP	Prints CLIP parameters.
PLOG	Prints log of the ICE-LOCK.
PCREF	Prints credit pars parameters.
PCN	Prints credit request numbers.
PCC1	Prints credit for ICE-LOCK (universal request).
PCC2	Prints credit for ICE-LOCK. (TIM Italy).
PCC3	Prints credit for ICE-LOCK. (VODAFONE Italy).
INS	Prints status of the inputs.
PORC	Prints (controls) the status of outputs.
PPIN	Prints PIN access codes.

Table 24: ICE-LOCK parameters print out commands

## 1 4 TECHNICAL SPECIFICATIONS

---

Description	Value
Power Supply	12 - 24V AC/DC
Current consumption - peak	2A
Current consumption - transmitting mode	300mA
Current consumption - idle mode with illuminated keypad	180mA
Quad band GSM module	850/900/1800/1900 MHz
PCB dimensions	82 × 75 mm
Unit dimensions	156 × 116 × 61 mm
External Patch Antenna SMA	1
Weight	500 g
Alarm inputs	1
Alarm relay outputs	1
12V DC Power Supply output (100mA max.)	Yes
12-24V AC/DC Power Supply input	Yes



## **TRANSMITTER SOLUTIONS WARRANTY**

The warranty period of this Transmitter Solutions product is twenty-four (24) months. This warranty shall begin on the date the product is manufactured. During the warranty period, the product will be repaired or replaced (at the sole discretion of Transmitter Solutions) if the product does not operate correctly due to a defective component. This warranty does not extend to (a) the product case, which can be damaged by conditions outside the control of Transmitter Solutions, or (b) battery life of the product. This warranty is further limited by the following disclaimer of warranty and liability:

EXCEPT AS SET FORTH ABOVE, TRANSMITTER SOLUTIONS MAKES NO WARRANTIES REGARDING THE GOODS, EXPRESS OR IMPLIED, INCLUDING WARRANTY OF MERCHANTABILITY OR WARRANTY OF FITNESS FOR A PARTICULAR PURPOSE. BUYER MAKES NO RELIANCE ON ANY REPRESENTATION OF TRANSMITTER SOLUTIONS, EXPRESS OR IMPLIED, WITH REGARD TO THE GOODS AND ACCEPTS THEM "AS-IS/WHERE-IS". TRANSMITTER SOLUTIONS SELLS THE GOODS TO BUYER ON CONDITION THAT TRANSMITTER SOLUTIONS WILL HAVE NO LIABILITY OF ANY KIND AS A RESULT OF THE SALE. BUYER AGREES THAT TRANSMITTER SOLUTIONS SHALL HAVE NO LIABILITY FOR DAMAGES OF ANY KIND, WHETHER DIRECT, INCIDENTAL OR CONSEQUENTIAL DAMAGES, INCLUDING INJURIES TO PERSONS OR PROPERTY, TO BUYER, ITS EMPLOYEES OR AGENTS, AS A RESULT OF THE SALE. BUYER ALSO AGREES TO HOLD TRANSMITTER SOLUTIONS HARMLESS FROM ANY CLAIMS BUYER, OR ANY THIRD PARTY, MAY HAVE AS A RESULT OF BUYER'S USE OR DISPOSAL OF THE GOODS. BUYER HAS READ THIS DISCLAIMER AND AGREES WITH ITS TERMS IN CONSIDERATION OF RECEIVING THE GOODS.



7380 S. Eastern Avenue, Suite 124-320 • Las Vegas, NV 89123  
(866) 975-0101 \* (866) 975-0404 Fax  
[www.transmittersolutions.com](http://www.transmittersolutions.com)