

LiftMaster

MYQ-SGC1WLM



Smart Garage Camera™ Installation Guide

Installation Video



See the Smart Garage Camera™ installation video at support.chamberlaingroup.com.



WARNING: This product can expose you to chemicals including lead, which are known to the State of California to cause cancer or birth defects or other reproductive harm. For more information go to www.P65Warnings.ca.gov

What's In the Box

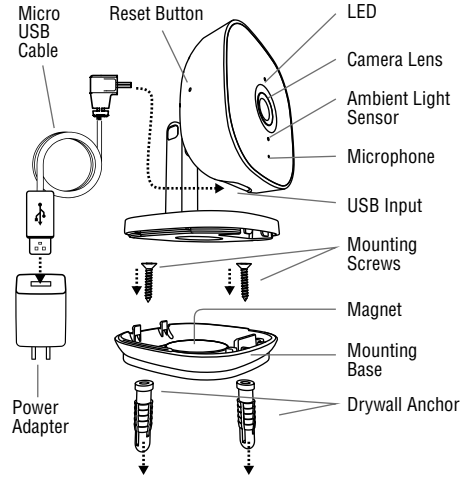

1. Connect Your Smart Garage Camera™

Use the myQ® App, your mobile device, and your router to control your Smart Garage Camera™.

Before You Start:

1. Be sure your mobile device's Wi-Fi® is on and displays a strong signal where the camera will sit.
2. Check that Bluetooth is enabled on your mobile device.
3. Enable Location Services on your mobile device.
4. Download the myQ® App.
TIP: If you already have the myQ® App, confirm you have the latest version to optimize your myQ® experience.
5. Create or sign in to your account.
6. Add your Smart Garage Camera™ to your myQ® account.

2. Preparation

Check Your View Before You Mount:

- Power up the Smart Garage Camera™ in your chosen mounting area.
- Smart Garage Camera™ is in reach of the included 10' (3 m) Micro-USB cable and a power outlet.
- Hold the camera at your chosen mounting area, free from visual and metal obstructions. Check your mobile device view shows what you want to see before you mount.
- If using the magnetic mounting base screws for a surface mount, mark the surface area to install.
- Power off the Smart Garage Camera™ by unplugging it to begin a surface mount.

3. Mount the Smart Garage Camera™

For Indoor Use Only

Items You May Need:

- Ladder
- Philips Screw Driver
- Drill and Drill Bit
- Hammer

Choose from Options A or B:

Option A: Magnetically Set to Garage Door Opener

1. Place the Smart Garage Camera™ magnetic mounting base on the garage door opener, with lens facing what you want to see.
2. Wrap the cable around the mounting base.

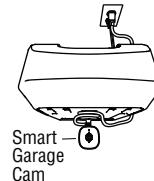

Option B: Surface Mount

1. Remove the magnetic mounting base from the Smart Garage Camera™ by pushing down on the rear tab and pulling downward.
2. Position the magnetic mounting base at the desired installation surface.
3. Insert screws provided with drywall anchors, as needed.
4. Reassemble the Smart Garage Camera™ over the magnetic mounting base.
5. Position the Smart Garage Camera™ with lens facing what you want to see.

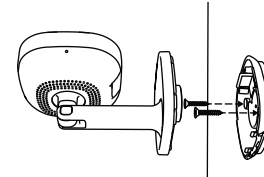

4. Connect Power

1. Power your Smart Garage Camera™ with the included micro-USB power adapter and cable. The LED lights solid white. After approximately 30 seconds, the LED flashes blue, blue-green, then solid green. You are now connected.
2. With your mobile device, access the **myQ® App | Devices** and select the Smart Garage Camera™ camera icon to view the live video.
3. Adjust the Smart Garage Camera™, twisting the possible camera head to change the viewing angle.

LED Status Indicators

What You See	What It Means
Solid White	Smart Garage Camera™ is powering up.
Flashing Blue	Ready to be set up in the myQ® App.
Solid Blue	Connected to your mobile device. You are not yet connected to the Internet. If this persists after setup, check your home router and Internet.
Flashing Blue and Green	Connecting to Wi-Fi and connecting to the myQ® App.
Flashing Green	Connected to the router, but there is no internet.
Solid Green	Connected to the myQ® App.
Flashing Purple	Receiving firmware updates.

One Year Limited Warranty

The Chamberlain Group, Inc. warrants to the first consumer purchaser of this product that it is free from defect in material and/or workmanship for a period of 1 year from the date of purchase.

Software Agreement

Use of this product and the software embedded within the product are subject to the copyright notices, terms, and conditions accessible in the myQ® App. Open the App Menu and select **Help**, and then **License and Terms of Use** for more information.

Need Help?

Go to: support.chamberlaingroup.com

NOTICE: This device complies with part 15 of the FCC rules and Innovation, Science and Economic Development Canada license-exempt RSSs. Operation is subject to the following two conditions: (1) this device may not cause harmful interference, and (2) this device must accept any interference received, including interference that may cause undesired operation. Any changes or modifications not expressly approved by the party responsible for compliance could void the user's authority to operate the equipment. This device must be installed to ensure a minimum 20 cm (8 in.) distance is maintained between users/bystanders and device. This device has been tested and found to comply with the limits for a Class B digital device, pursuant to part 15 of the FCC rules and Industry Canada ICES standard. These limits are designed to provide reasonable protection against harmful interference in a residential installation. This equipment generates, uses and can radiate radio frequency energy and, if not installed and used in accordance with the instructions, may cause harmful interference to radio communications. However, there is no guarantee that interference will not occur in a particular installation. If this equipment does cause harmful interference to radio or television reception, which can be determined by turning the equipment off and on, the user is encouraged to try to correct the interference by one or more of the following measures:

- Reorient or relocate the receiving antenna.
- Increase the separation between the equipment and receiver.
- Connect the equipment into an outlet on a circuit different from that to which the receiver is connected.
- Consult the dealer or an experienced radio/TV technician for help.

This device, which transmits within the band 5150-5250 MHz, is for indoor use only. This is to reduce the potential for harmful interference to co-channel mobile satellite systems.